

Operating manual

Device control unit EMS-1040 / EMS-1080



Rev 1.2

Legal information

All rights reserved. No part of this manual may be reproduced or duplicated in any form without prior consent of Beckmann GmbH. Beckmann GmbH is not liable with respect to the buyer of this product or to third parties for damage, loss, costs or expenses incurred as a result of accidents, misuse of the product, unauthorized changes, repairs or additions. Furthermore, Beckmann GmbH is not liable for losses, costs, malfunctions or consequential damage arising from the use of the device control unit. The technical data correspond to the current state at the time of printing. Printing errors, mistakes and amendments reserved.

Beckmann GmbH

Brandtstraße 1
33161 Hövelhof
Phone: +49 (0) 52 57 - 98 23 – 0
Fax: +49 (0) 52 57 - 98 23 – 11
info@beckmann-gmbh.de
www.beckmann-gmbh.de

Table of contents

1	Notes on using the operating instructions	1-1
1.1	Symbols	1-2
1.1.1	Symbols for personal protective equipment	1-2
1.1.2	Hazard symbols	1-2
1.1.3	Notice symbol	1-2
1.2	Validity of these instructions – name plate	1-3
1.3	Limitation of liability	1-4
1.4	Customer service	1-4
2	Technical information	2-1
2.1	Functional description	2-1
2.2	Equipment	2-1
2.3	Technical data	2-2
2.3.1	Dimensions	2-3
2.4	Device depiction	2-4
3	Safety	3-1
3.1	Intended use	3-2
3.2	Improper use	3-2
3.3	Personnel requirements	3-3
3.4	Operator responsibilities	3-4
3.5	Safety information	3-4
3.6	Residual risks	3-5
3.7	Safety signs and labels at the device control unit	3-6
4	Transport and storage	4-1
4.1	Scope of delivery	4-1
4.2	Transportation	4-1
4.3	Storage	4-1
5	Set-up and installation	5-1
5.1	Instructions for unpacking	5-1
5.2	Safety measures prior to installation	5-1
5.3	Requirements at the installation site	5-1
5.4	Installation of the operating unit	5-2
5.4.1	Electrical connection of the operating unit	5-4
5.5	Installation of the PowerBox	5-7
5.5.1	Electrical installation of the PowerBox	5-7
5.6	Connection of terminal devices	5-7
6	Start-up and operation	6-1
6.1	Start-up	6-1
6.2	Operation	6-2
6.2.1	Inserting coins or tokens	6-2
6.2.2	RFID	6-3
6.2.3	Credit card terminal „Nayax“	6-4
6.2.4	Setting the coin validator	6-8
6.2.5	Emptying the coin box	6-9
6.3	Shutdown	6-10
7	Programming	7-1
7.1	Requirements	7-1
7.2	Navigation	7-3
7.3	Programming a car wash	7-4

Table of contents

7.3.1	Menu structure car wash	7-4
7.3.2	Parameters car wash	7-7
7.3.3	Exemplary programming car wash	7-12
7.4	Programming a washing machine	7-15
7.4.1	Menu structure washing machine	7-15
7.4.2	Parameters washing machine	7-18
7.4.3	Exemplary programming washing machine	7-24
7.5	Programming WC/washing machine	7-26
7.5.1	Menu structure WC/washing machine	7-26
7.5.2	Parameters WC/washing machine	7-29
7.5.3	Exemplary programming WC/washing machine	7-34
7.6	Programming a charging station	7-36
7.6.1	Menu structure charging station	7-36
7.6.2	Parameters charging station	7-39
7.6.3	Exemplary programming charging station	7-45
8	Maintenance	8-1
8.1	Safety	8-1
8.2	Maintenance schedule	8-2
8.3	Maintenance activities	8-2
8.3.1	Cleaning the housing	8-2
8.3.2	Cleaning the coin validator	8-3
9	Faults	9-1
9.1	Safety	9-1
9.2	Fault table	9-2
10	Disposal	10-1
11	Annex	11-3
11.1	Declaration of Conformity	11-3
11.2	Stainless steel cleaning and maintenance instructions	11-5
11.3	Supplier documentation	11-7
11.3.1	EMP coin validator	11-7

1	Notes on using the operating instructions	
Fig. 1-1	Name plate EMS 1040	1-3
Fig. 1-2	Name plate EMS 1080	1-3
2	Technical information	
Fig. 2-1	Dimensions device control unit	2-3
Fig. 2-2	Overview master tower	2-4
Fig. 2-3	Overview control box Isobox	2-5
3	Safety	
Fig. 3-1	Warning sign PowerBox	3-6
4	Transport and storage	
5	Set-up and installation	
Fig. 5-1	Unlocking lid	5-2
Fig. 5-2	Opening the hinged cover	5-2
Fig. 5-3	Attaching the device control unit	5-3
Fig. 5-4	Diagram GDM plugs and bus cable	5-4
Fig. 5-5	Opening the Isobox	5-5
Fig. 5-6	Piercing through the splash guard grommet	5-5
Fig. 5-7	Connecting the 230 V supply line	5-6
Fig. 5-8	Terminal plan	5-6
6	Start-up and operation	
Fig. 6-1	Display and selection buttons for the devices	6-2
Fig. 6-2	Inserting a coin	6-2
Fig. 6-3	Using an RFID card	6-3
Fig. 6-4	Cancel selection	6-4
Fig. 6-5	Display and selection buttons for the devices	6-5
Fig. 6-6	Time selection	6-5
Fig. 6-7	Using a credit card on Nayax terminal	6-6
Fig. 6-8	Opening the lock	6-8
Fig. 6-9	Opening hinged cover.	6-8
Fig. 6-10	Opening lock	6-9
Fig. 6-11	Opening hinged cover.	6-9
7	Programming	
Fig. 7-1	Opening lock	7-1
Fig. 7-2	Opening hinged cover.	7-1
Fig. 7-3	Programming switch	7-2
Fig. 7-4	Navigation in programming mode	7-3
Fig. 7-5	Terminal assignment single point operation car wash	7-12
Fig. 7-6	Diagram time course for single point operation car wash	7-13
Fig. 7-7	Terminal assignment car wash operation car wash	7-13
Fig. 7-8	Diagram time course for single point operation car wash	7-14
Fig. 7-9	Terminal assignment application of washing machine	7-24
Fig. 7-10	Example 1: Standard time operation washing machine	7-24
Fig. 7-11	Example 2: Door opening washing machine	7-25
Fig. 7-12	Port assignment application of WC/washing machine	7-34
Fig. 7-13	Example 1, pulse mode: 4-operation => P8 pulse time = 5 s	7-35
Fig. 7-14	Example 2, time mode: 4-operation => P8 pulse time = 0 s	7-35

Table of figures

Fig. 7-15	Terminal assignment for the application of a charging station	7-45
Fig. 7-16	Diagram time course for the application of a charging station	7-45

8 Maintenance

Fig. 8-1	Opening lock	8-3
Fig. 8-2	Opening hinged cover.	8-3

9 Faults

10 Disposal

11 Annex

1 Notes on using the operating instructions

In this operating manual the user obtains information

- for his own safety,
- for a quicker familiarization with the functional range of the device control unit,
- for safe working with the device control unit,
- for remedying faults and
- for maintaining the device control unit.

In order to maintain the reliability of the device control unit, to increase its life cycle and to prevent downtimes, observe the instructions in the operating manual.

Study the "Safety" chapter thoroughly.

The arrangements and functions of all components must be known prior to initial commissioning of the device control unit.

Observe the information provided in the operating manual for all works.

Moreover, always observe the applicable accident prevention and environmental protection regulations as well as the generally recognized technical rules for safe and proper working.

Feel free to contact us if there are any unresolved issues after having read the operating manual.

The illustrations in the operating manual may differ from the actual design. The factual information content remains unaffected.

1.1 Symbols

Particularly important information in this operating manual are marked with the following symbols:

1.1.1 Symbols for personal protective equipment



Wear protective gloves.



Wear safety boots.

1.1.2 Hazard symbols



Danger!

This symbol combined with the signal word indicates an imminent danger to the life and health of persons.

The texts marked with this symbol and signal word provide information on how to prevent personal injury.



Warning!

This symbol combined with the signal word indicates a danger resulting in minor to moderate injuries.

The texts marked with this symbol and signal word provide information on how to prevent personal injury.



Caution!

This symbol indicates the danger of property damage.

The texts marked with this symbol and signal word provide information on how to prevent property damage.

If the source of danger can be clearly defined, the corresponding pictogram precedes the hazard warning:



Danger!

Hazardous electric voltage.

This symbol indicates dangers due to electric voltage.

1.1.3 Notice symbol



Note

This symbol indicates application tips or general information.

1.2 Validity of these instructions – name plate

This operating manual is valid for the device control unit EMS-1040 / EMS-1080 (hereinafter referred to as control unit) with the following name plates:

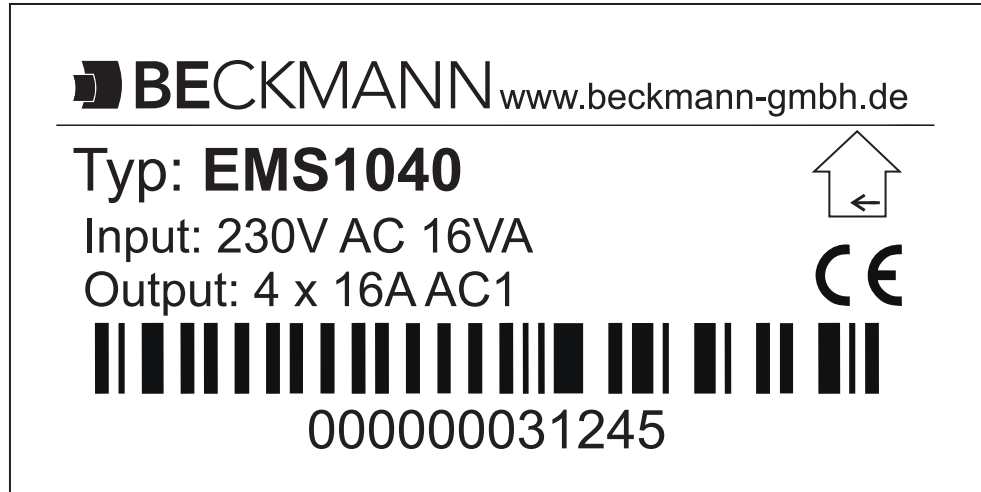

Fig. 1-1 Name plate EMS 1040

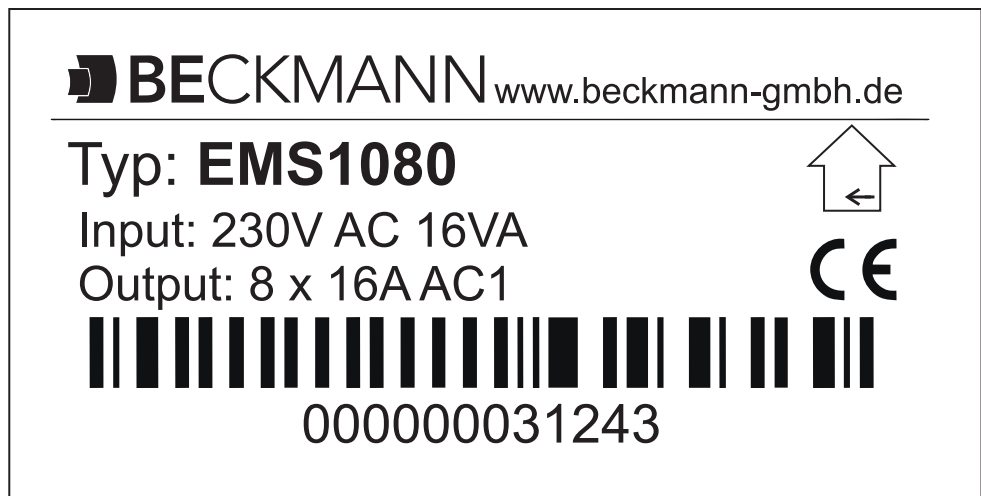

Fig. 1-2 Name plate EMS 1080

1.3 Limitation of liability

Beckmann GmbH is not liable with respect to the buyer of this product or to third parties for damage, loss, costs or expenses incurred as a result of accidents, misuse of the product, unauthorized changes, repairs or additions. Furthermore, Beckmann GmbH is not liable for losses, costs, malfunctions or consequential damage arising from the use of the device control unit. The technical data correspond to the current state at the time of printing. Printing errors, mistakes and amendments reserved.

All of the specifications and information in this manual have been compiled in due consideration of the applicable standards and regulations, the state of the art and our many years of experience and findings.

The manufacturer assumes no liability for damages resulting from:

- the non-observance of these operating instructions
- improper use
- the deployment of unqualified personnel
- unauthorised alterations
- technical changes
- the use of non-approved spare and wear parts
- vandalism

The actual scope of delivery may differ from the descriptions and illustrations in this manual in case of special designs, when making use of additional order options or due to the latest technical modifications.

Apart from that, the obligations agreed upon in the delivery contract, the general terms and conditions as well as the manufacturer's delivery conditions and the legal provisions valid upon conclusion of the contract apply.

1.4 Customer service

Beckmann GmbH
Brandtstraße 1
33161 Hövelhof

Phone: +49 (0) 52 57 - 98 23 - 0

Fax: +49 (0) 52 57 - 98 23 - 11

info@beckmann-gmbh.de

www.beckmann-gmbh.de

2 Technical information

2.1 Functional description

The devices of the EMS-1040/EMS-1080 system family have been developed for the central control of up to eight terminal devices (in the HDR version of up to eight programmes).

The robust housing construction made of high-quality stainless steel impresses with a timeless design while offering protection against extreme weather conditions and vandalism.

The multicoloured status LEDs above the keyboard indicate which terminal devices are free and allow the customer to make an individual choice. The large display shows the respective minimum amount of insertion (different prices can be set for each terminal device/programme).

A system always consists of two components:

- Operating unit (for selection, payment, settings)
- PowerBox (including voltage supply, relay outputs)

The separate PowerBox supplies the operating unit with low voltage, thus ensuring a secure outdoor installation.

The fields of application include:

- Central control of up to 8 showers
- Central control of up to 8 vacuum cleaners
- Central control of up to 8 washing machines
- Programme control for car washes (HDR version)

2.2 Equipment

The device control unit is available in the following versions:

- EMS-1040 for up to 4 terminal devices
- EMS-1080 for up to 8 terminal devices
- EMS-1040 HDR for up to 4 cleaning programmes
- EMS-1080 HDR for up to 8 cleaning programmes

In the HDR version (for high-pressure cleaners) up to eight programmes can be selected, which are subsequently transferred to the terminal device.

2.3 Technical data

Tab. 2-1 Technical data

Parameter	Value	
Type designation	EMS-1040	EMS-1080
Energy supply	230 V AC / 50 Hz	
Power consumption	max. 10 W	
Relay outputs	4 x	8 x
Switching capacity per relay	16 A, 250 V AC	
Housing material	V2A stainless steel	
Temperature area of application	-20 to +40 °C	
Type of protection	from IP44 (depending on installation)	
Dimensions operating unit (width x height x depth)	320 mm x 300 mm x 155 mm	
Dimensions PowerBox (width x height x depth)	255 mm x 180 mm x 105mm	
Weight operating unit	7 kg	
Weight PowerBox	1 kg	

2.3.1 Dimensions

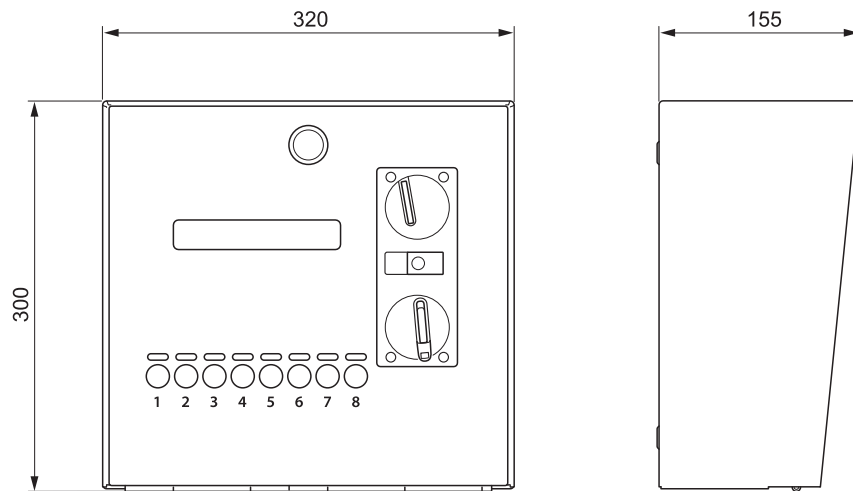

Fig. 2-1 Dimensions device control unit

2.4 Device depiction

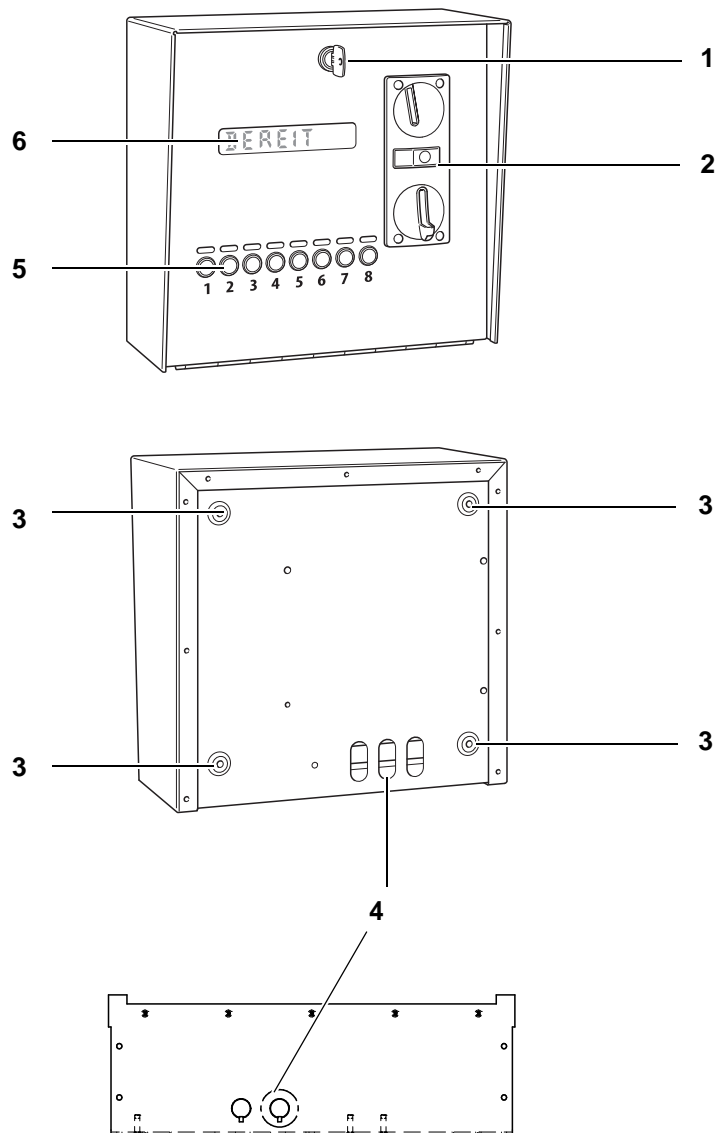

Fig. 2-2 Overview master tower

No.	Designation
1	Lock / closure for the front cover
2	Coin slot with protective flap
3	Screw holes for wall mounting
4	Connections for PowerBox and terminal devices (3 at the rear, 2 with strain relief at the bottom)
5	Control panel with LEDs and selection buttons
6	Display

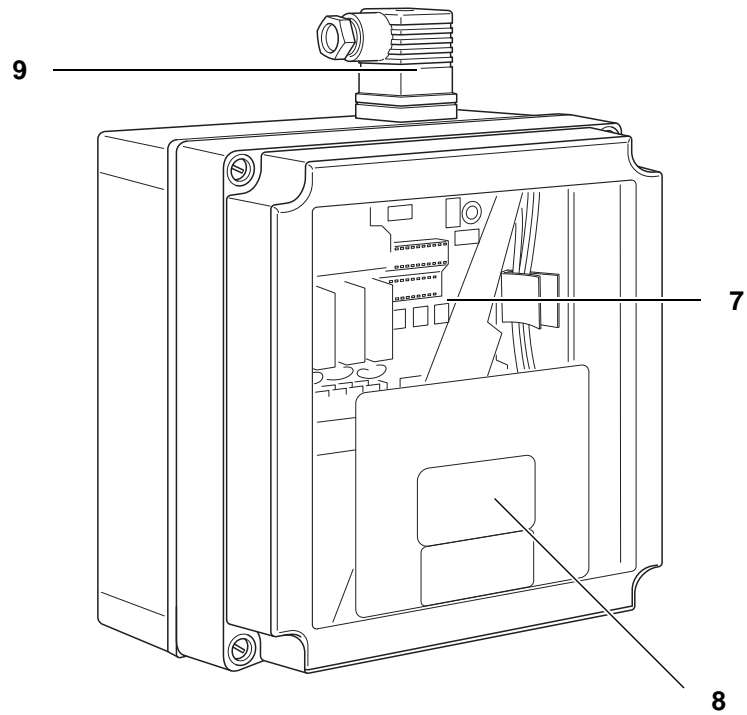

Fig. 2-3 Overview control box Isobox

No.	Designation
7	PowerBox
8	Warning sign and wiring diagram (inside)
9	Connection for device control unit

3 Safety

This device complies with the relevant safety regulations for measuring and control technology and has been constructed in accordance with state-of-the-art technology and the recognised safety rules and regulations. Nevertheless, its use may result in danger for life and limb of the user or third parties or cause damage to the device and other assets.

Only use this device in perfect condition, in accordance with regulations, fully aware of safety and dangers and observing these operating instructions!

Have all faults, especially those which may jeopardise safety, repaired immediately!

In addition to the operating manual also observe the generally applicable legal and other binding accident prevention and environmental protection regulations!

Do not change or modify the device control unit without prior consent of the manufacturer!

Spare parts must meet the requirements specified by the manufacturer! This is only guaranteed when using original spare parts.

Observe the deadlines for recurring maintenance intervals specified in this operating manual!

Ensure the safe and environmentally sound disposal of plastic parts and electronic replacement parts!

3.1 Intended use

The device control unit EMS 1040/ EMS 1080 is only intended for the control and operation of:

- high-pressure cleaners
- vacuum cleaners
- showers
- washing machines
- car washes
- door locks
- sockets
- lockers

Intended use also includes the observance of these operating instructions and maintenance intervals.

3.2 Improper use

The device control unit EMS 1040/ EMS 1080 must not be used for controlling systems other than those specified in the intended use.

The connection of terminal devices with an amperage above 16 A is prohibited.

3.3 Personnel requirements

The device control unit may only be operated by personnel who have been instructed by either Beckmann GmbH, authorised specialist companies, their service partners or the operator and who have read and understood the operating manual.

Electrically skilled person

Electrically qualified personnel must be able to read and understand electric circuit diagrams, to commission and maintain electrical systems, to wire switch and control cabinets, to install controlling software, to ensure proper functioning of electrical components and to identify possible hazards in the work with electric and electronic systems.

Instructed person

Instructed persons are informed of the tasks assigned to them as well as of potential hazards of inappropriate behaviour by the operator. These persons are only allowed to perform service tasks (e. g. money collection).

The device is to be maintained and looked after by instructed personnel.

Tab. 3-1 Overview of the minimum required personnel qualifications

Activities	Instructed persons	Electrically skilled person
Transportation	X	
Assembly, mounting	X	
Electrical installation		X
Start-up		X
Shutdown	X	
Disassembly	X	
Electrical deinstallation		X
Cleaning	X	
Maintenance		X
Troubleshooting, repair		X
Disposal	X	

3.4 Operator responsibilities

The operator is responsible for the regular assignment of safety-related checks, maintenance and service tasks. The operator must also ensure that the personnel has been trained in working with the device and that this operating manual is available at the operating site at all times. The operator must only use this device as intended. The operator may only use this device in perfect condition; this condition is to be checked at regular intervals. In case of any deviations operation is to be stopped immediately.

All faults, especially those which may jeopardise safety, have to be repaired immediately.

The operator has to fulfil the legal obligations in terms of occupational safety. In addition to the information on occupational safety provided in this manual the national safety, accident prevention and environmental protection regulations applicable for the field of application must be complied with.

3.5 Safety information

**Danger!**

Risk of death due to electrical voltage!

The device control unit must be de-energized before undertaking any work.

Shut the device control unit down according to chapter 6.3, page 6-10 and consult an electrically skilled person!

**Warning!**

Danger of minor injuries due to sharp edges or falling objects!

Wear your personal protective equipment.

**Caution!**

Property damage owing to the use of wrong cleaning agents!

Only use the cleaning agents specified in the maintenance chapter to clean the tower!

Never use a high-pressure cleaner to clean the tower!

**Caution!**

Property damage due to improper use

The device control unit is not suitable for terminal devices utilizing it in any other way than intended. Terminal devices with an amperage above 16 A must not be connected.

When connecting an improper terminal device, both the device control unit and the connected device may be damaged.

3.6 Residual risks

The following residual risks result from the installation in a public place:

**Caution!**

Property damage due to incorrect use.

Never use tools or other objects to operate the device control unit. Never try to change or repair any part of the device control unit.

If the device control unit does not function properly, immediately inform the operator!

3.7 Safety signs and labels at the device control unit

The following safety signs and labels at the device control unit are to be checked on a regular basis. If they are illegible, they must be replaced:

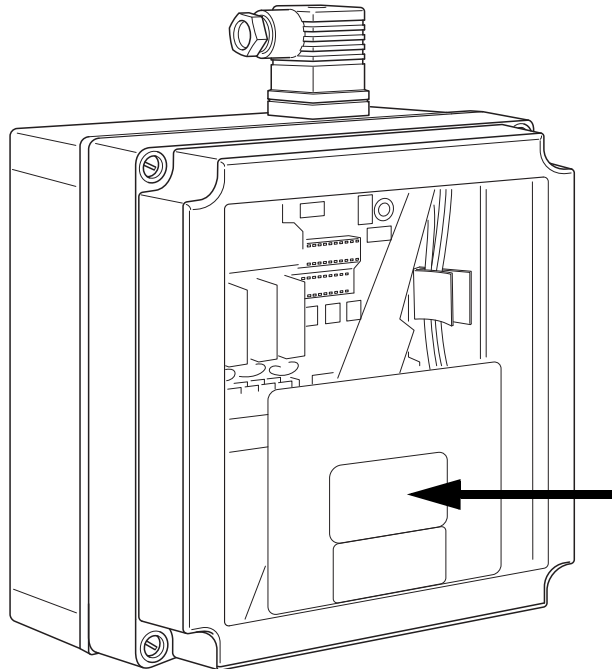
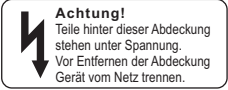

Fig. 3-1 Warning sign PowerBox

Warning sign	Designation
	<p>Caution! There are live parts behind this cover. Only remove it after having disconnected the device from the mains.</p>

4 Transport and storage

After delivery check the device control unit for visible transport damages and immediately report these to the supplier and Beckmann GmbH.

4.1 Scope of delivery

The device control unit delivery consists of the following components:

- operating unit
- PowerBox
- 2 keys
- coin box
- IP splash guard cover (optional)
- 2 GDM plug connectors
- 10 m bus cable

4.2 Transportation

The device control unit is to be transported as closely as possible to the installation site.

4.3 Storage

All components of the device control unit are to be stored in a dry place, under a roof and at an ambient temperature of 10 to 40 °C to prevent the penetration of moisture into the parts' interior.

Observe the maintenance instructions for stainless steel in chapter 11.2, page 11-5.

5 Set-up and installation

Before set-up and installation read the safety chapter.

5.1 Instructions for unpacking

- Remove the packing material from all parts.

5.2 Safety measures prior to installation

- Disconnect the supply line from the mains.
- Disconnect the terminal devices.

5.3 Requirements at the installation site

The following requirements must be satisfied before set-up and installation of the device control unit:

- If the operating unit is set up outdoors, the IP splash guard must be used.
- The PowerBox must be set up near the power supply, e. g. in an equipment room.
- Observe the maintenance instructions for stainless steel in chapter 11.2, page 11-5.

5.4 Installation of the operating unit

Requirements:

- The supply line and the terminal devices are de-energized.

1. Open the lock (10) at the front of the operating unit.

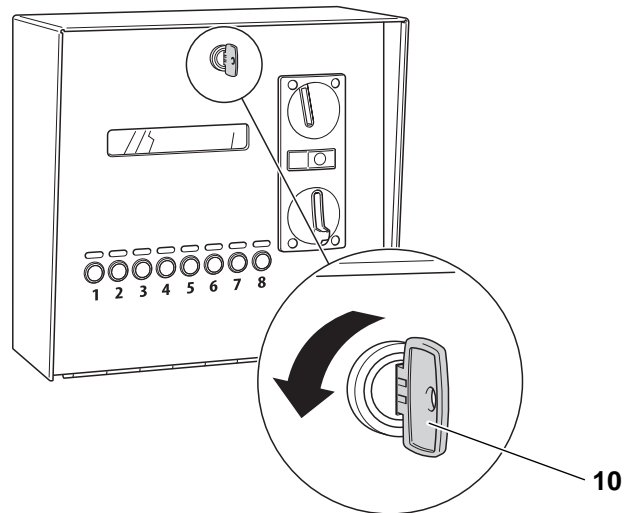

Fig. 5-1 Unlocking lid

2. Open the hinged cover to the front.

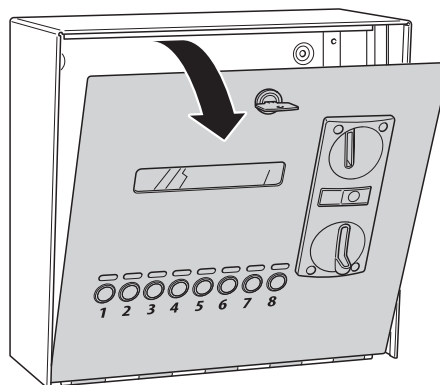

Fig. 5-2 Opening the hinged cover

**Warning!**

Danger of minor injuries due to sharp edges or falling objects!
Wear your personal protective equipment.

3. Position the operating unit at the installation site.
4. Mark the position of the boreholes through the 4 screw holes (3) at the rear.

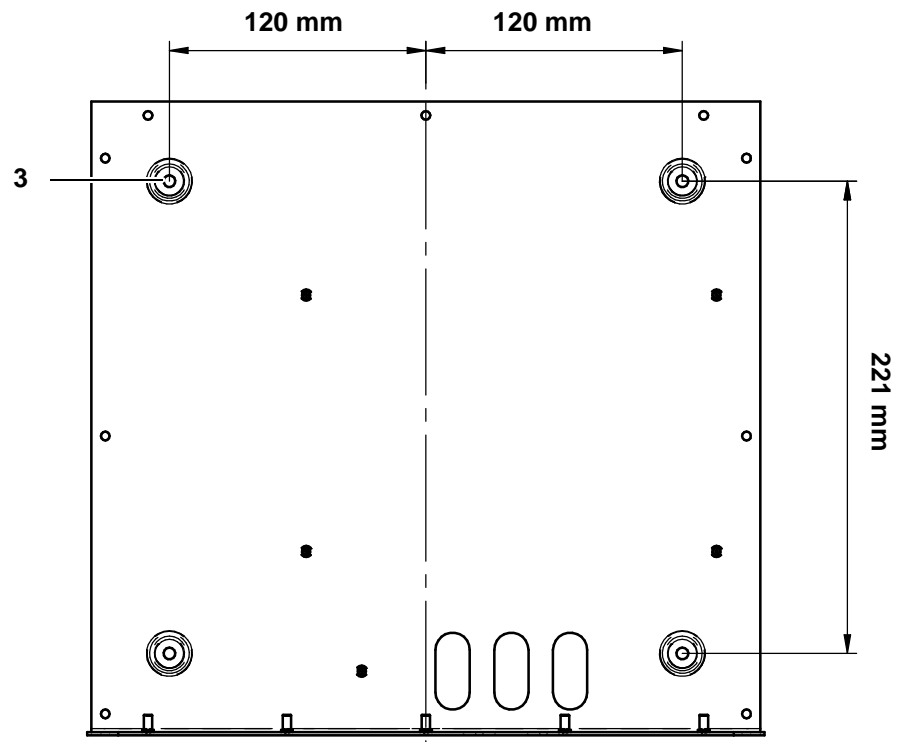

Fig. 5-3 Attaching the device control unit

5. Depending on the structure of the wall, use suitable size 6 dowels and screws (not included in the scope of delivery).
6. Attach the operating unit to the wall.

**Note!**

The electrical connection must be performed by an electrically skilled person.

5.4.1 Electrical connection of the operating unit

**Note!**

The electrical connection must be performed by an electrically skilled person.

Requirements:

- The supply line is de-energized.
- A shielded cable with GDM plugs is ready for use.

1. Install the supplied connection cable between operating unit and PowerBox.

Note!

If the supplied 10 m cable is too short, use a corresponding BELDEN cable with the respective shielding and dimensions.

2. Run the connection cable into the operating unit from the rear or from below.
 - Use the holes on the rear and bottom sides of the housing.
 - Make sure you use the supplied strain relief device and edge protection.
 - Do not kink the cable excessively and avoid crushing the cable when closing the cover.
3. Connect the GDM plug to both cable ends according to the following wiring diagram.

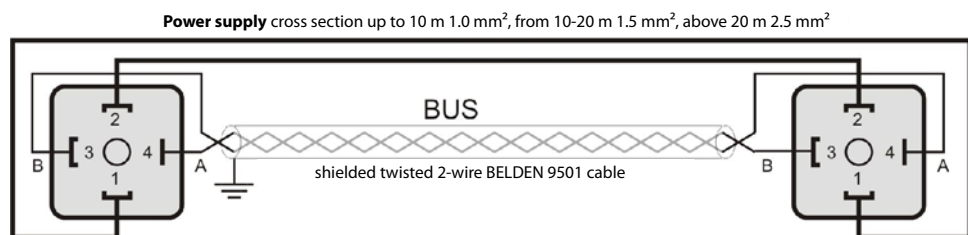

Fig. 5-4 Diagram GDM plugs and bus cable

4. Attach the shielding to the housing of the operating unit.
5. Plug in both GDM plugs (note the coding) and screw them together.

6. Once the electronic system is de-energized, open the Isobox cover by loosening the four Phillips screws and removing the cover.

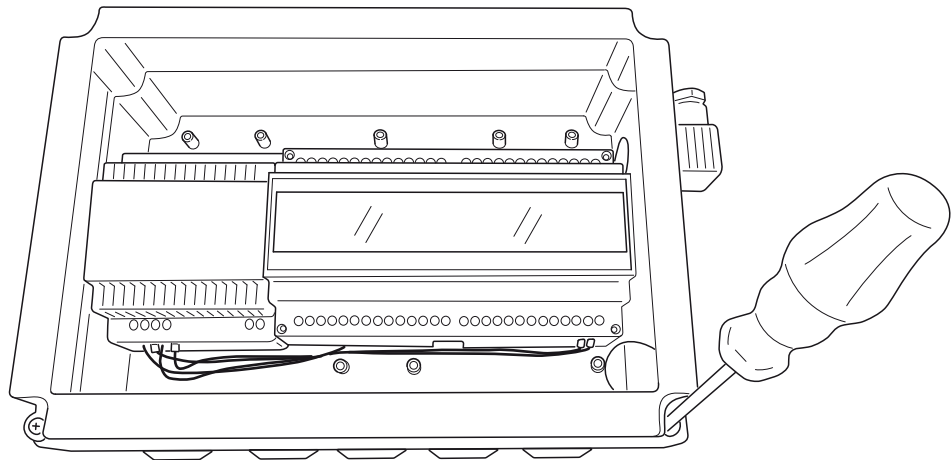

Fig. 5-5 Opening the Isobox

7. Use a suitable tool (e. g. a screwdriver) to pierce through the splash guard grommet for the supply line on the Isobox.
 - The opening in the splash guard grommet should not be too large in order to maintain an effective splash protection.

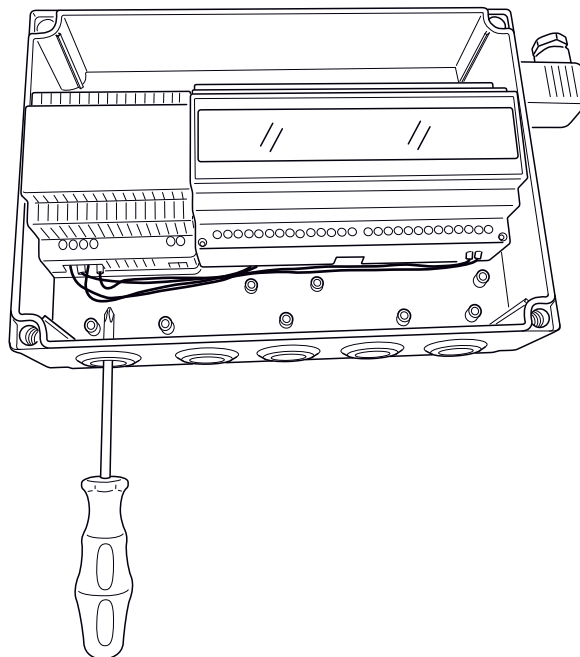

Fig. 5-6 Piercing through the splash guard grommet

8. Guide a 230 V supply line through the splash guard grommet of the PowerBox and connect L/N/PE.
 - A strain relief must be established.
 - The grommet must closely surround the cable.

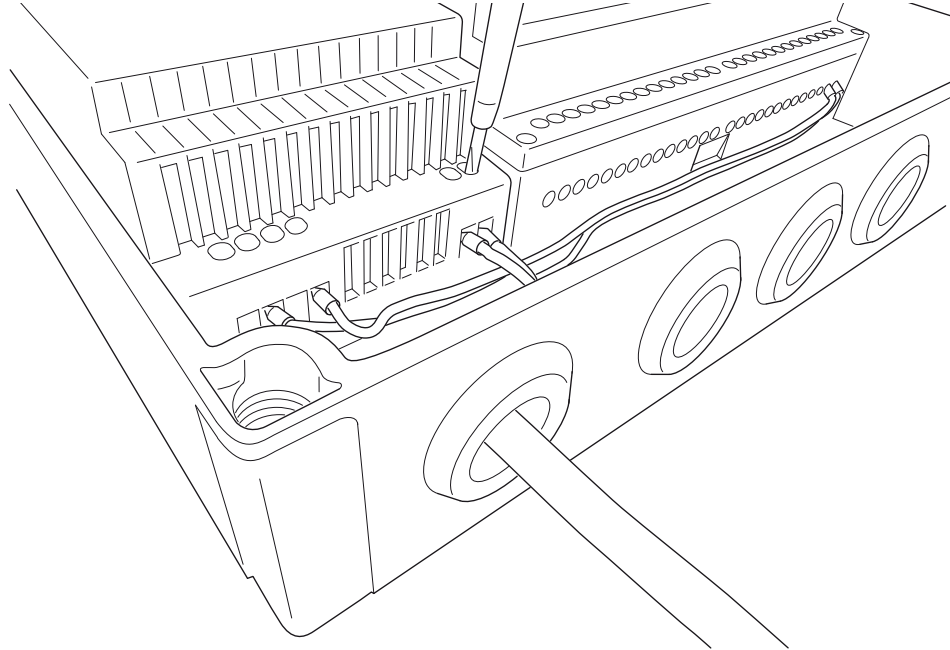

Fig. 5-7 Connecting the 230 V supply line

9. Connect the components to be controlled to the pluggable screw terminals of the relay inputs and outputs.
 - The connection of the components/programmes to be controlled depends on the version and will be explained in more detail in chapter 7, page 7-1.

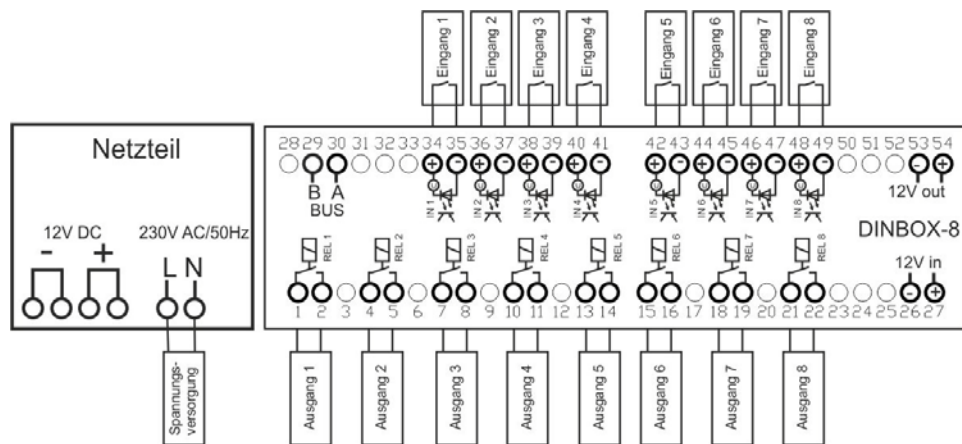

Fig. 5-8 Terminal plan

10. Put the Isobox cover back in place and fix it with the 4 screws.
 - Check for tightness in order to ensure an effective splash protection.
11. Close the housing cover.
12. Use the key to lock it.
 - The installation is now completed.
 - The device control unit is ready for start-up.

5.5 Installation of the PowerBox

The PowerBox is set up separately inside a dry room, preferably near the power supply of the terminal devices.

5.5.1 Electrical installation of the PowerBox

**Note!**

The electrical connection must be performed by an electrically skilled person.

See chapter 5.4.1, page 5-4.

5.6 Connection of terminal devices

**Note!**

The electrical connection must be performed by an electrically skilled person.

Please observe the following when connecting terminal devices to the device control unit:

- The terminal devices must be checked for connection compatibility with the potential-free contacts of the device control unit.
- Make sure that the cables are undamaged and the cable connections and guidances are tight when laying cables outdoors.
- Provide a strain relief for the cable connections.
- Finally, have the installation inspected and approved by a qualified electrician.

6 Start-up and operation

Before start-up read the "Safety" chapter.

6.1 Start-up

Requirements:

- The device control unit has been set up and installed according to chapter 5.
- The terminal devices have been connected.
- It has been inspected and approved by a qualified electrician.

1. Connect the terminal devices to the voltage supply.
2. Plug the mains plug of the PowerBox into a sufficiently fused power socket.

6.2 Operation

6.2.1 Inserting coins or tokens

6.2.1.1 Booking a programme, device or product

3. Press a selection button with a green LED on the operating unit.
 - The assignment of the selection buttons can be gathered from the posting or inquired of the operator.

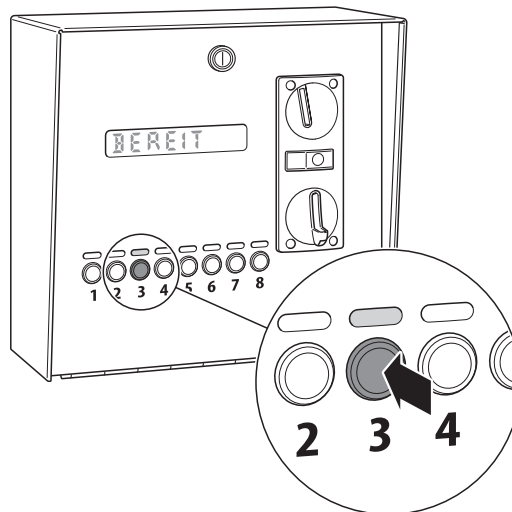

Fig. 6-1 Display and selection buttons for the devices

4. Insert a coin or token into the coin slot.

The prices for programmes, devices or products can be gathered from the posting or inquired of the operator.

 - The corresponding number is released and the matching programme/device/product can be used.

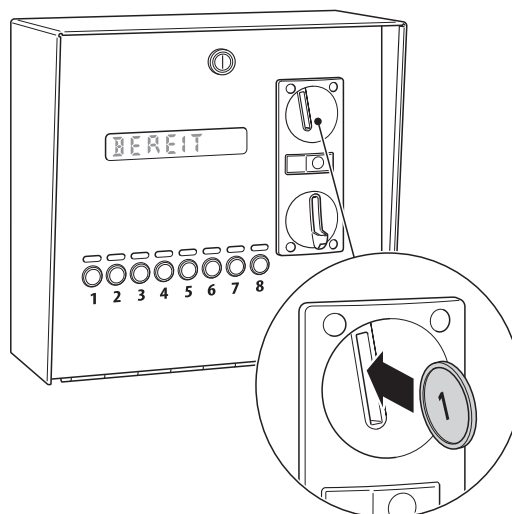

Fig. 6-2 Inserting a coin

6.2.1.2 Topping up your credit balance

1. Press the selection button with the corresponding socket number.
2. Open the protective flap covering the coin slot.
3. Insert a coin.

The balance will be recalculated and indicated on the display.

6.2.1.3 Checking your credit balance

1. Press the selection button with the corresponding socket number.
 - The remaining balance is indicated on the display.

6.2.2 RFID

The RFID reading device at the operating unit indicates its status by means of illuminated LEDs; their meaning is as follows:

Colour	Status	Meaning
white	illuminated	ready for operation
red	illuminated	fault
with held up RFID card:		
red	illuminated	socket already in use
red	flashing	RFID card invalid or cannot be read
green	illuminated	socket booked or released

6.2.2.1 Booking a programme, device or product

1. Press a selection button with a green LED on the operating unit.
 - The assignment of the selection buttons can be gathered from the posting or inquired of the operator.
2. Hold your RFID card up against the reader.

The prices for programmes, devices or products can be gathered from the posting or inquired of the operator.

 - The corresponding number is released and the matching programme/device/product can be used.

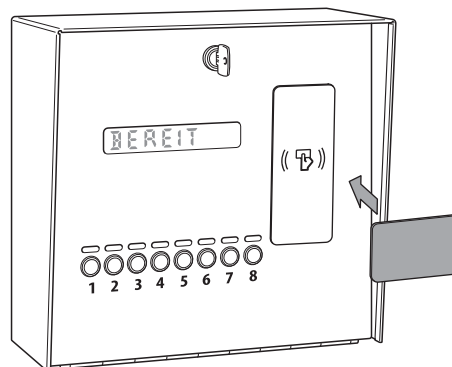

Fig. 6-3 Using an RFID card

6.2.2.2 Releasing a programme, device or product

1. Select the booked socket via the selection button.
2. Hold the RFID card used for booking up against the reader.
 - The programme, device or product is released and can be booked again.

**Note!**

If the credit on the RFID card is used up before releasing, the programme, device or product is no longer available and will automatically be released for further booking.

6.2.3 Credit card terminal „Nayax“

The „Nayax“ credit card terminal at the operating unit indicates its status by means of illuminated LEDs. Commands are visible in the display as well as acoustic output is provided. The „Nayax“ antenna must be placed outside the control unit for a good signal reception. If the signal is too weak for a robust functionality, provide an internet connection via LAN cable.

6.2.3.1 Booking a programme, device or product

1. Any selection can be cancelled by pressing the „C“ button.

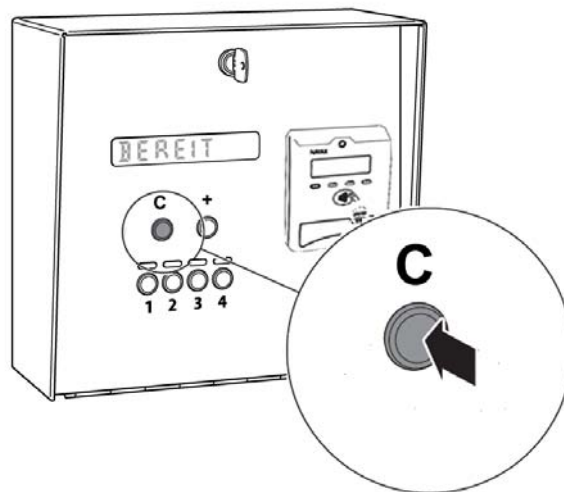

Fig. 6-4 Cancel selection

2. Press a selection button with a green LED on the operating unit to select a free programme/ device/ programme.
 - The assignment of the selection buttons can be gathered from the posting or inquired of the operator.

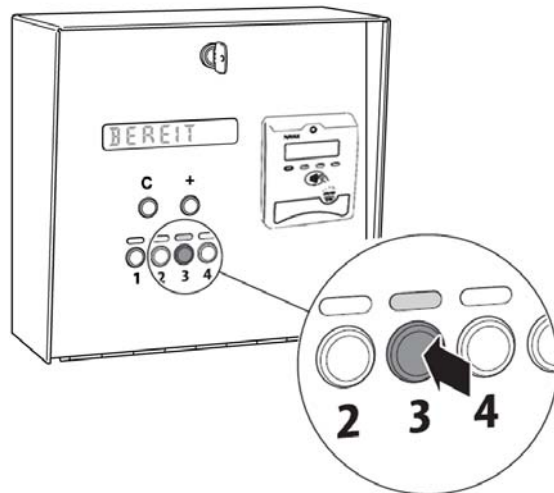

Fig. 6-5 Display and selection buttons for the devices

3. In the case of time selling functionality (e.g. as shower control), the minimum time must be selected by pressing the „+“ button one time. To increase the wanted time, repeat to press the „+“ button until the wanted time is reached.

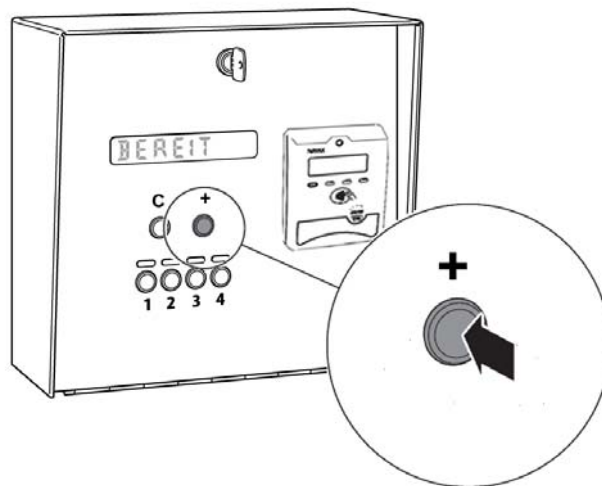

Fig. 6-6 Time selection

4. Hold your credit card up against the reader (or swipe it or stick it in the reader).

The prices for programmes, devices or products can be gathered from the posting or inquired of the operator.

- As the „Nayax“ credit card terminal is designed for micropayments, the maximum payment amount is limited to a maximum amount per transaction (depends on local regulation, more information can be gathered from the local provider). If this amount is exceeded, payment process will be aborted.
- The corresponding number is released and the matching programme/device/product can be used.

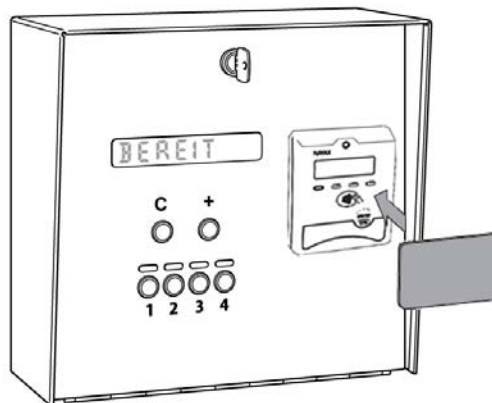

Fig. 6-7 Using a credit card on Nayax terminal

6.2.3.2 Releasing a programme, device or product

1. Select the booked socket via the selection button.
2. To book additional time, repeat to press the „+“ button until the wanted additional time is reached.
3. Hold your credit card up against the reader (or swipe it or stick it in the reader).
 - As the „Nayax“ credit card terminal is designed for micropayments, the maximum payment amount is limited to a maximum amount per transaction (depends on local regulation, more information can be gathered from the local provider). If this amount is exceeded, payment process will be aborted.

The balance will be recalculated and indicated on the display.

6.2.3.3 Checking your credit balance

1. Press the selection button with the corresponding socket number.
 - The remaining balance is indicated on the display.

6.2.4 Setting the coin validator

1. Open the lock (30) at the front of the device control unit.

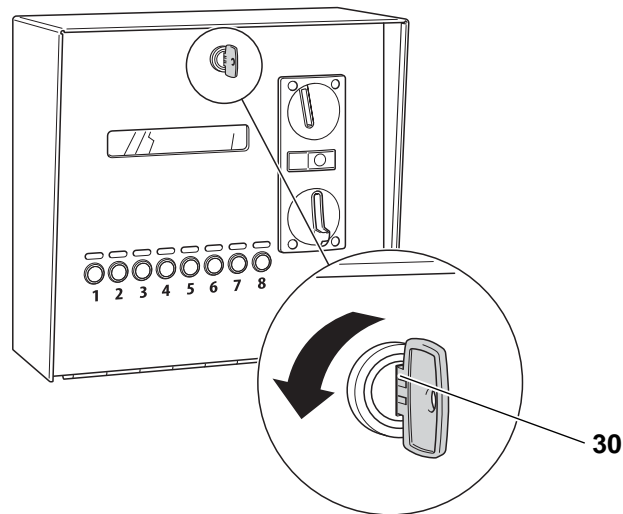

Fig. 6-8 Opening the lock

2. Open the hinged cover to the front.

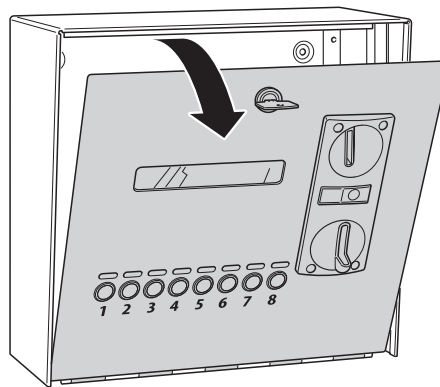

Fig. 6-9 Opening hinged cover.

3. Remove the coin validator.
4. For information on how to set the coin validator please consult the coin validator's supplier instructions, see chapter 11.3.1, page 11-7.
5. Close the cover again.
6. Use the key to lock it.

6.2.5 Emptying the coin box

1. Open the lock (30) at the front of the device control unit.

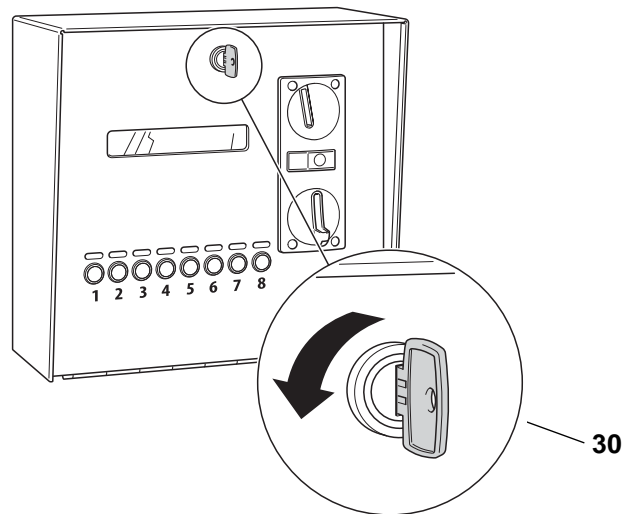

Fig. 6-10 Opening lock

2. Open the hinged cover.

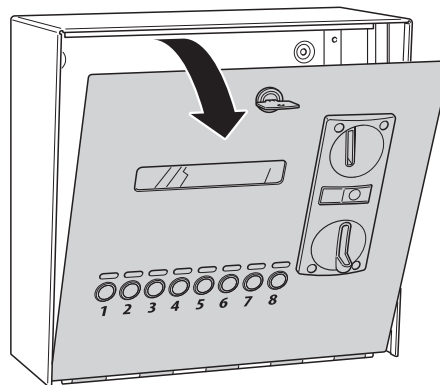

Fig. 6-11 Opening hinged cover.

3. Remove the coin box.
4. Empty the contents of the coin box out into a suitable container.
5. Reinsert the coin box.
6. Close the cover and lock it up.

6.3 Shutdown

1. Disconnect the PowerBox from the power supply.
2. Disconnect the cable connection between PowerBox and operating unit.
3. Disconnect the cable connection between operating unit and terminal devices.
 - The device control unit is rendered inoperative.

7 Programming

Programming the device control unit enables the setting of different rates and programmes at different times (timer).

The programming is either preset by the specialist dealer or may be effected by the operator.

7.1 Requirements

Before you can start with the programming, the device control unit first has to be set to programming mode. To do so, please proceed as follows:

1. Open the lock (10) at the front of the operating unit.

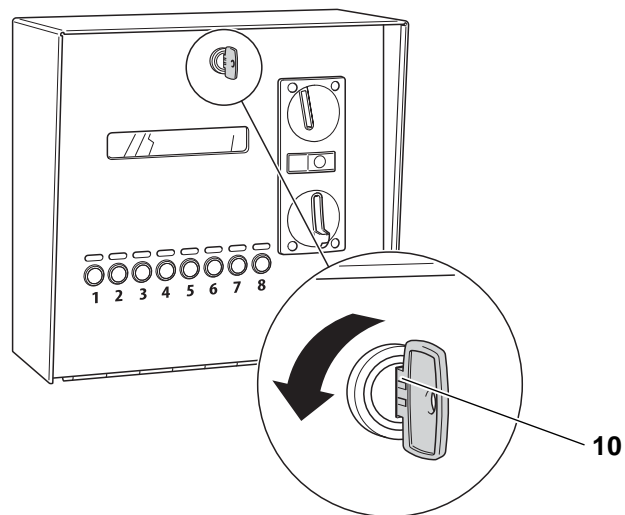

Fig. 7-1 Opening lock

2. Open the hinged cover.

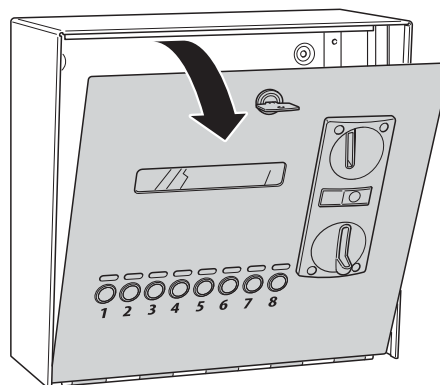

Fig. 7-2 Opening hinged cover.

3. Switch the programming switch (70) to ON.
 - Credit balance that has already been booked keeps running during programming mode.
 - It is not possible to book new devices while in programming mode.
 - It is not possible to top up your credit for already booked devices while in programming mode.
 - The red LEDs above button 3 (EMS-1040) or 5 (EMS-1080) are illuminated.

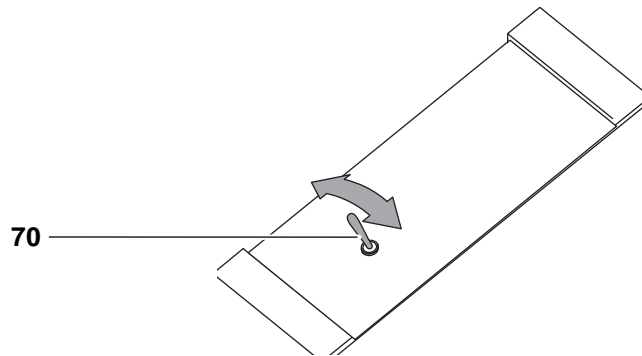

Fig. 7-3 Programming switch

4. Press the button with the red LEDs to confirm.
 - Programming mode is started.
 - For further steps, please refer to chapter 7.2, page 7-3.
5. To exit programming mode, set the programming switch back to OFF position.
6. Close the device control unit again once the programming has been completed.

7.2 Navigation

The selection buttons at the front of the device control unit are to be used for menu navigation.

The four centre selection buttons are available. When programming mode is started, the two outer selection buttons light up in **red**, the inner two in **green**.

- Using outer two buttons you can navigate within a menu. Also the parameter values can be changed via these buttons. For the purpose of navigation these buttons are called Plus (71) and Minus (74).
- By use of the two inner buttons you can change the menu levels. For the purpose of navigation these buttons are called Next (72) and Previous (73).

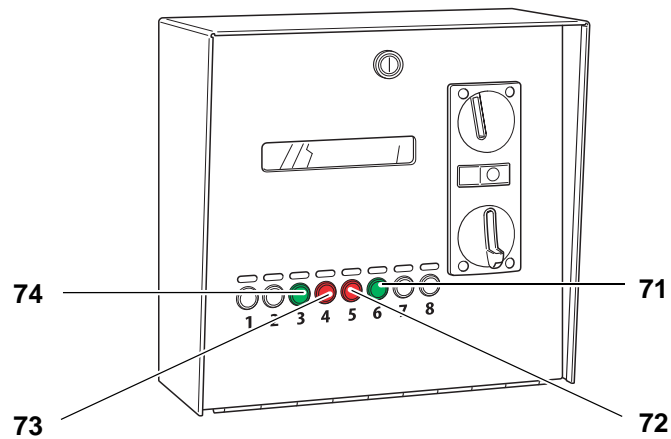

Fig. 7-4 Navigation in programming mode

No.	Designation
71	Plus key
72	Next key
73	Previous key
74	Minus key

7.3 Programming a car wash

The following chapter describes the menu structure, parameters and exemplary programming for the application of a car wash.

7.3.1 Menu structure car wash

The menu structure is made up of seven superordinate menus. Each menu comes with parameters that can be set. Further information on the parameters are provided in chapter 7.3.2.

7.3.1.1 Menu 1 – counters total

The parameters shaded in grey are optional. These parameters will only be active with an RFID card system.

1 – counters total				
Parameter	P1	P2	P3	P4
Name	registers sum 1	registers sum 2	cards sum 1	cards sum 2
Function Plus key	-	-	-	-
Function Minus key	delete	-	delete	-
Default value	€0.00	€0.00	€0.00	€0.00
Parameter	P5	P6	P7	P8
Name	tokens sum 1	tokens sum 2	uses sum 1	usages sum 2
Function Plus key	-	-	-	-
Function Minus key	delete	-	delete	-
Default value	0	0	0	0

7.3.1.2 Menu 2 – prices and power

2 – prices and power	
Parameter	P1
Name	standard price
Function Plus key	+ €0.10
Function Minus key	- €0.10
Default value	€1.00

7.3.1.3 Menu 3 – clock & display

Parameter	P1	P2	P3	P4
Name	hours	minutes	weekday	day
Function Plus key	+ 1 h	+ 1 min	+ 1 weekday	+ 1 day
Function Minus key	- 1 h	- 1 min	- 1 weekday	- 1 day
Default value	-	-	-	-
Parameter	P5	P6	P7	
Name	month	year	clock display	
Function Plus key	+ 1 month	+ 1 year	yes	
Function Minus key	- 1 month	- 1 year	no	
Default value	-	-	no	

7.3.1.4 Menu 4 – operation

The parameters shaded in grey are optional. These parameters will only be active with an RFID card system.

4 – operation					
Parameter	P1	P3	P4	P5	P6
Name	operation	Unit price valid?	token value	adding token value to register	token reset
Function Plus key	yes	yes	+ €0.10	yes	yes
Function Minus key	no	no	- €0.10	no	no
Default value	yes	no	€1.00	no	no
Parameter	P7	P8	P9	P10	P11
Name	debiting step	pulse time	maximum overpayment	BCD output	change of sum
Function Plus key	+ €0.01	+1	+ €0.10	yes	yes
Function Minus key	- €0.01	- 1	- €0.10	no	no
Default value	€1.00	5 s	€0.50	no	no
Parameter	P12	P13	P14		
Name	single payment	basic setting	deleting card no.		
Function Plus key	yes	yes	yes		
Function Minus key	no	-	-		
Default value	no	-	-		

7.3.1.5 Menu 5 – information

The parameters shaded in grey are optional. These parameters will only be active with an RFID card system.

5 – information				
Parameter	P1	P2	P3	P4
Name	software version	serial number	card no. 1	card no. 2
Function Plus key	-	-	-	-
Function Minus key	-	-	-	-
Default value	-	-	-	-
Parameter	P5	P6	P7	
Name	card no. 3	card no. 4	card no. 5	
Function Plus key	-	-	-	
Function Minus key	-	-	-	
Default value	-	-	-	

7.3.1.6 Menu 6 – network

The parameters shaded in grey are optional. These parameters will only be active with an RFID card system.

6 – network				
Parameter	P1	P2 - P5	P6 - P9	P10 - P13
Name	register number	IP address	subnet	gateway
Function Plus key	+ 1	-	-	-
Function Minus key	- 1	-	-	-
Default value	200	-	-	-

7.3.1.7 Menu 7 – programme 1 to 4/8

The parameters shaded in grey are optional. Parameter 3 will only be active with an RFID card system. Parameter 7 will only be available if *Menu 4 - P3 Unit price valid?* is set to "no".

7 – programme 1 to 4/8				
Parameter	P1	P2	P3	P4
Name	test run	register cash	register card	register tokens
Function Plus key	+ 0.3 kWh	-	-	-
Function Minus key	emergency stop	delete	delete	delete
Default value	-	€0.00	€0.00	0
Parameter	P5	P6	P7	
Name	number of uses	operation	standard price	
Function Plus key		yes	+ €0.10	
Function Minus key	delete	no	- €0.10	
Default value	0	yes	€0.50	

7.3.2 Parameters car wash

In this chapter the parameters of the menu structure are described in detail.
When a parameter is referred to, the systematic is as follows: "*menu number*" - "*parameter number*" "*parameter name*".

7.3.2.1 Menu 1 – counters total

- **P1 registers sum 1**
This parameter indicates the amount in euros inserted in the coin slot since the last counter clearing.
Pressing the Minus key sets the cash position back to €0.00.
- **P2 registers sum 2**
This parameter indicates the amount in euros inserted in the coin slot since the start-up.
This parameter cannot be reset.
- **P3 cards sum 1**
This parameter indicates the turnover in euros generated by means of RFID cards since the last counter clearing.
Pressing the Minus key sets the counter reading back to €0.00.
This parameter will only be active with an RFID card system.
- **P4 cards sum 2**
This parameter indicates the turnover in euros generated by means of RFID cards since the start-up.
This parameter cannot be reset.
This parameter will only be active with an RFID card system.
- **P5 tokens sum 1**
This parameter indicates the number of tokens inserted in the coin slot since the last counter clearing.
Pressing the Minus key sets the counter reading back to 0.
- **P6 tokens sum 2**
This parameter indicates the number of tokens inserted in the coin slot since the start-up.
This parameter cannot be reset.
- **P7 uses sum 1**
This parameter indicates the number of bookings made on the device control unit since the last counter clearing.
Pressing the Minus key sets the counter reading back to 0.
- **P8 consumption sum 2**
This parameter indicates the number of bookings made on the device control unit since the start-up.
This parameter cannot be reset.

7.3.2.2 Menu 2 – prices and power

These settings can only be viewed when *Menu 4 – P3 – unit price* is activated.

- **P1 standard price**

The standard price is the minimum amount that has to be paid to book the selected port.

7.3.2.3 Menu 3 – clock and display

- **P1 hours**

Here the current time is set (hours).

- **P2 minutes**

Here the current time is set (minutes).

- **P3 weekday**

Here the current weekday is set.

- **P4 day**

Here the current date is set.

- **P5 month**

Here the current month is set.

- **P6 year**

Here the current year is set.

- **P7 clock display**

With an activated clock display the time is displayed during operation of the tower.

7.3.2.4 Menu 4 – operation

- **P1 operation**

By means of this parameter you set whether the device control unit is to be in operation or not. When the device control unit is deactivated, booking is disabled. In that event inserted coins will be returned immediately.
- **P3 Unit price valid?**

If this parameter is set to "yes", the prices set in menu 2 apply for all the available ports at the device control unit.
If the parameter is set to "no", individual prices and energy amounts can be set in the respective programme menus starting from menu 7...
- **P4 token value**

This parameter defines the equivalent value of a token in euros. This value is used for booking according to the rate settings.
- **P5 adding token value to register**

If this parameter is activated, the set token value of each inserted token is added to the register.
- **P6 token reset**

If this parameter is set to "yes", the selected outlet will be released upon insertion of a token and the remaining credit will be deleted.
If this option is used, tokens will generally not be accepted as paying medium any more.
- **P7 debiting step**

This parameter will only be active with an RFID card system.
- **P8 impulses per unit**

Depending on type and manufacturer, the integrated electricity meters can emit a different number of impulses to the interface S0. The most common values can be set in this parameter. The value may only be changed if one electricity meter was exchanged for another with a different number of pulses.
- **P9 maximum overpayment**
- **P10 BCD output**
- **P11 change of sum**
- **P12 single payment**

- **P13 basic setting**
If this parameter is activated, the device control unit will be reset to the factory setting.
- **P14 delete card no.**
If this parameter is activated, the system's card number will be deleted, so that a new card number can be configured, e.g. when losing a system card. This parameter will only be active with an RFID card system.

7.3.2.5 Menu 5 – information

- **P1 software version**
This parameter indicates the installed software version.
- **P2 serial number**
This parameter indicates the individual serial number of the tower.
- **P3 card no. 1**
Relevant to the RFID reader version: This parameter indicates the no. of special card 1.
This parameter will only be active with an RFID card system.
- **P4 card no. 2**
Relevant to the RFID reader version: This parameter indicates the no. of special card 2.
This parameter will only be active with an RFID card system.
- **P5 card no. 3**
Relevant to the RFID reader version: This parameter indicates the no. of special card 3.
This parameter will only be active with an RFID card system.
- **P6 card no. 4**
Relevant to the RFID reader version: This parameter indicates the no. of special card 4.
This parameter will only be active with an RFID card system.
- **P7 card no. 5**
Relevant to the RFID reader version: This parameter indicates the no. of special card 5.
This parameter will only be active with an RFID card system.

7.3.2.6 Menu 6 – network

This menu is only available for device control units with network connection (online version). This menu is only active with an RFID card system.

- **P1 register number**
These parameters indicate the register number.
- **P2-5 IP address**
These parameters indicate the IP address.
- **P6-9 subnet**
These parameters indicate the subnet.
- **P10-13 gateway**
This parameter indicates the gateway.

7.3.2.7 Menu 7 – programme 1 to 4/8

The following parameters refer to the programme positions 1 to 4 or 8. "X" is used as wildcard in place of the programme number.

- **P1 test run**
This parameter serves for the individual function test of programme X. By pressing the Plus key an energy amount of 0.3 kWh is credited to the account of programme X. With every subsequent actuation the account is credited with another 0.3 kWh.
Pressing the Minus key aborts this process, the credit will be deleted and the port will be released again.
- **P2 register cash**
Indicates the amount of euros inserted as coins for booking programme X since the least counter clearing.
This parameter is set back to 0 when reset is initiated in
Menu 1 – registers sum 1.
- **P3 register card**
Indicates the amount of euros put to use for booking programme X by means of RFID cards since the least counter clearing.
This parameter is set back to 0 when reset is initiated in
Menu 1 – registers sum 1.

- P4 register tokens**
 Indicates the amount of euros inserted as tokens for booking programme X since the least counter clearing.
 This parameter is set back to 0 when reset is initiated in *Menu 1 – tokens sum 1.*
- P5 number of uses**
 Indicates the number of uses of programme X since the last counter clearing.
 This parameter is set back to 0 when reset is initiated in *Menu 1 – uses sum 1.*
- P6 operation**
 By means of this parameter you set whether programme X is to be in operation or not.
- P7 standard price**
 This menu item can only be adjusted if *Menu 4 - P3 Unit price valid?* is set to "no".
 The standard price is the minimum amount that has to be paid to book programme X. If the customer pays more than this amount, more energy will be credited to him.

7.3.3 Exemplary programming car wash

The following exemplary programmings show the respective terminal assignments and signal paths in relation to time.

7.3.3.1 Single point operation

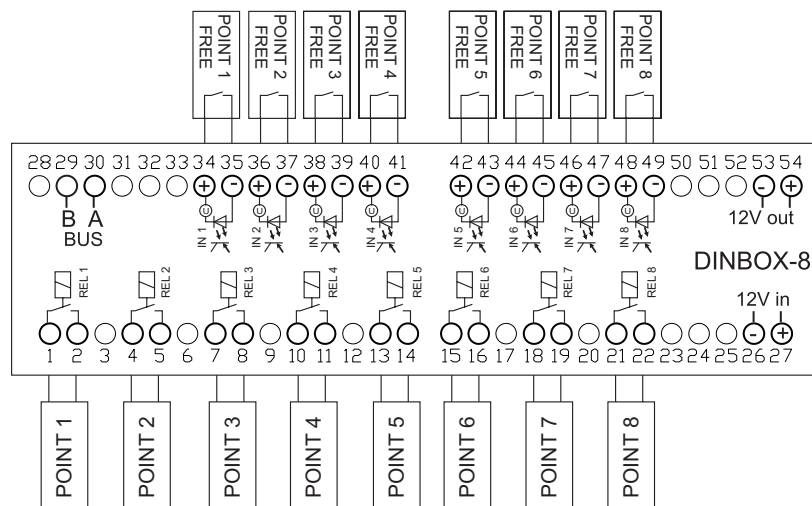

Fig. 7-5 Terminal assignment single point operation car wash

"Free" signal

If the point is ready for operation, the input must be inactive, i. e. the contact must be open. Selecting and paying for the point will then be enabled on the machine.

If the contact is closed, it is not possible to make a selection or payment. As long as the point is used, the terminal device must give the signal *in use* and the contact must be closed.

Start signal potential-free

After full payment for a point has been made, the respective contact is closed for 1 second.

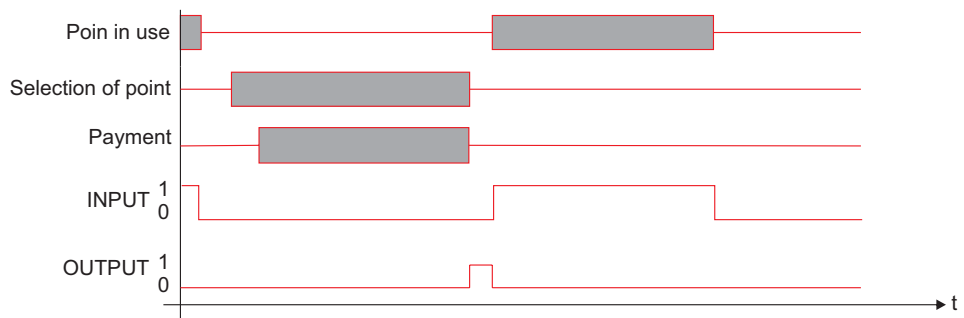

Fig. 7-6 Diagram time course for single point operation car wash

7.3.3.2 Car wash operation

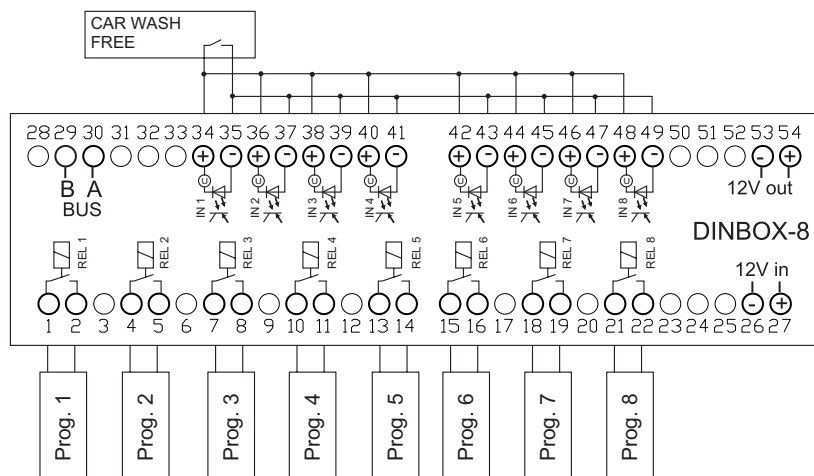

Fig. 7-7 Terminal assignment car wash operation car wash

"Free" signal

If the system is ready for operation, the input must be inactive, i. e. the contact must be open. Selecting and paying for the point will then be enabled on the machine.

If the contact is closed, it is not possible to make a selection or payment. As long as the port is used, the terminal device must give the signal *in use* and the contact must be closed.

Start signal potential-free

After full payment for a programme has been made, the respective contact is closed for 1 second (optionally 8 programmes encoded via REL. 1-4 BCD).

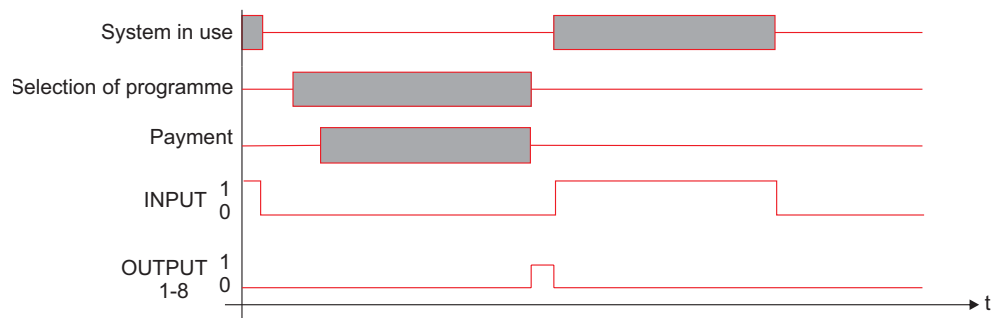

Fig. 7-8 Diagram time course for single point operation car wash

7.4 Programming a washing machine

The following chapter describes the menu structure, parameters and exemplary programming for the application of a washing machine.

7.4.1 Menu structure washing machine

The menu structure is made up of seven superordinate menus. Each menu comes with parameters that can be set. Further information on the parameters are provided in chapter 7.4.2.

7.4.1.1 Menu 1 – counters total

The parameters shaded in grey are optional. These parameters will only be active with an RFID card system.

1 – counters total				
Parameter	P1	P2	P3	P4
Name	registers sum 1	registers sum 2	cards sum 1	cards sum 2
Function Plus key	-	-	-	-
Function Minus key	delete	-	delete	-
Default value	€0.00	€0.00	€0.00	€0.00
Parameter	P5	P6	P7	P8
Name	tokens sum 1	tokens sum 2	operating time sum 1	operating time sum 2
Function Plus key	-	-	-	-
Function Minus key	delete	-	delete	-
Default value	0	0	0	0

7.4.1.2 Menu 2 – prices and power

2 – prices and power			
Parameter	P1	P3	P4
Name	standard price	time	maximum time
Function Plus key	+ €0.10	+ 10 s	+ 1 min
Function Minus key	- €0.10	- 10 s	- 1 min
Default value	€0.50	1:00 min	4:00 h

7.4.1.3 Menu 3 – clock & display

Parameter	P1	P2	P3	P4	P5
Name	hours	minutes	weekday	day	month
Function Plus key	+ 1 h	+ 1 min	+ 1 weekday	+ 1 day	+ 1 month
Function Minus key	- 1 h	- 1 min	- 1 weekday	- 1 day	- 1 month
Default value	-	-	-	-	-
Parameter	P6	P7	P8	P10	
Name	year	clock display	sum display	second display	
Function Plus key	+ 1 year	yes	yes	yes	
Function Minus key	- 1 year	no	no	no	
Default value	-	no	no	no	

7.4.1.4 Menu 4 – operation

The parameters shaded in grey are optional. These parameters will only be active with an RFID card system.

4 – operation				
Parameter	P1	P2	P3	P4
Name	operation	Switch on everything	Unit price valid?	token value
Function Plus key	yes	yes	yes	+ €0.10
Function Minus key	no	no	no	- €0.10
Default value	yes	no	no	€1.00
Parameter	P5	P6	P7	P10
Name	adding token value to register	token reset	debiting step	number of door openings
Function Plus key	yes	yes	+ €0.01	+1
Function Minus key	no	no	- €0.01	- 1
Default value	no	no	€1.00	3
Parameter	P11	P12	P13	P14
Name	door opening time	door opening blocking time	basic setting	card no. delete
Function Plus key	+1	+1	yes	yes
Function Minus key	- 1	- 1	-	-
Default value	10 s	1 min	-	-

7.4.1.5 Menu 5 – information

The parameters shaded in grey are optional. These parameters will only be active with an RFID card system.

5 – information				
Parameter	P1	P2	P3	P4
Name	software version	serial number	card no. 1	card no. 2
Function Plus key	-	-	-	-
Function Minus key	-	-	-	-
Default value	-	-	-	-
Parameter	P5	P6	P7	
Name	card no. 3	card no. 4	card no. 5	
Function Plus key	-	-	-	
Function Minus key	-	-	-	
Default value	-	-	-	

7.4.1.6 Menu 6 – network

The parameters shaded in grey are optional. These parameters will only be active with an RFID card system.

6 – network				
Parameter	P1	P2 - P5	P6 - P9	P10 - P13
Name	register number	IP address	subnet	gateway
Function Plus key	+ 1	-	-	-
Function Minus key	- 1	-	-	-
Default value	200	-	-	-

7.4.1.7 Menu 7 – programme 1 to 4/8

The parameters shaded in grey are optional. Parameter 3 will only be active with an RFID card system. Parameter 7, 9 and 11 will only be available if *Menu 4 - P3 unit price valid?* is set to "no".

7 – device 1 to 4/8					
Parameter	P1	P2	P3	P4	P5
Name	test run	register cash	register card	register tokens	operating hours
Function Plus key	+ 0.3 kWh	-	-	-	-
Function Minus key	emergency stop	delete	delete	delete	delete
Default value	-	€0.00	€0.00	0	0 Wh
Parameter	P6	P7	P9	P11	P12
Name	operation	standard price	time	max.	paying extra
Function Plus key	yes	+ €0.10	+ 10 s	+ 1 min	yes
Function Minus key	no	- €0.10	- 10 s	- min	no
Default value	yes	€0.50	1:00 min	4:00 h	yes

7.4.2 Parameters washing machine

In this chapter the parameters of the menu structure are described in detail. When a parameter is referred to, the systematics is as follows: "*menu number*" - "*parameter number*" "*parameter name*".

7.4.2.1 Menu 1 – counters total

- **P1 registers sum 1**
This parameter indicates the amount in euros inserted in the coin slot since the last counter clearing.
Pressing the Minus key sets the cash position back to €0.00.
- **P2 registers sum 2**
This parameter indicates the amount in euros inserted in the coin slot since the start-up.
This parameter cannot be reset.
- **P3 cards sum 1**
This parameter indicates the turnover in euros generated by means of RFID cards since the last counter clearing.
Pressing the Minus key sets the counter reading back to €0.00.
This parameter will only be active with an RFID card system.
- **P4 cards sum 2**
This parameter indicates the turnover in euros generated by means of RFID cards since the start-up.
This parameter cannot be reset.
This parameter will only be active with an RFID card system.
- **P5 tokens sum 1**
This parameter indicates the number of tokens inserted in the coin slot since the last counter clearing.
Pressing the Minus key sets the counter reading back to 0.
- **P6 tokens sum 2**
This parameter indicates the number of tokens inserted in the coin slot since the start-up.
This parameter cannot be reset.
- **P7 operating time sum 1**
This parameter indicates the operating time since the last counter clearing.
Pressing the Minus key sets the counter reading back to 0.
- **P8 operating time sum 2**
This parameter indicates the operating time since the start-up.
This parameter cannot be reset.

7.4.2.2 Menu 2 – prices and power

These settings can only be viewed when *Menu 4 – P3 – unit price* is activated.

- **P1 standard price**
The standard price is the minimum amount that has to be paid to book the selected port.
- **P2 time**
Here the time released for the sums set in *P1 (standard price)* is defined (in min).
- **P3 maximum time**
This parameter stipulates the maximum time that can be booked through paying.

7.4.2.3 Menu 3 – clock and display

- **P1 hours**
Here the current time is set (hours).
- **P2 minutes**
Here the current time is set (minutes).
- **P3 weekday**
Here the current weekday is set.
- **P4 day**
Here the current date is set.
- **P5 month**
Here the current month is set.
- **P6 year**
Here the current year is set.
- **P7 clock display**
With an activated clock display the time is displayed during operation of the tower.
- **P8 sum display**
With an activated sum display the sum is displayed during operation of the tower.
- **P11 second display**

7.4.2.4 Menu 4 – operation

- **P1 operation**

By means of this parameter you set whether the device control unit is to be in operation or not. When the device control unit is deactivated, booking is disabled. In that event inserted coins will be returned immediately.
- **P2 switch on everything**

When this parameter is active, all ports/terminal devices are enabled and can be used without paying (construction site operation, cleaning operation).
- **P3 Unit price valid?**

If this parameter is set to "yes", the prices set in menu 2 apply for all the available ports at the device control unit.
If the parameter is set to "no", individual prices and energy amounts can be set in the respective programme menus starting from menu 7...
- **P4 token value**

This parameter defines the equivalent value of a token in euros. This value is used for booking according to the rate settings.
- **P5 adding token value to register**

If this parameter is activated, the set token value of each inserted token is added to the register.
- **P6 token reset**

If this parameter is set to "yes", the selected outlet will be released upon insertion of a token and the remaining credit will be deleted.
If this option is used, tokens will generally not be accepted as paying medium any more.
- **P7 debiting step**

This parameter will only be active with an RFID card system.
- **P10 number of door openings**
- **P11 door opening time**
- **P12 door opening blocking time**
- **P13 basic setting**

If this parameter is activated, the device control unit will be reset to the factory setting.
- **P14 delete card no.**

If this parameter is activated, the system's card number will be deleted, so that a new card number can be configured, e.g. when losing a system card.
This parameter will only be active with an RFID card system.

7.4.2.5 Menu 5 – information

- **P1 software version**
This parameter indicates the installed software version.
- **P2 serial number**
This parameter indicates the individual serial number of the tower.
- **P3 card no. 1**
Relevant to the RFID reader version: This parameter indicates the no. of special card 1.
This parameter will only be active with an RFID card system.
- **P4 card no. 2**
Relevant to the RFID reader version: This parameter indicates the no. of special card 2.
This parameter will only be active with an RFID card system.
- **P5 card no. 3**
Relevant to the RFID reader version: This parameter indicates the no. of special card 3.
This parameter will only be active with an RFID card system.
- **P6 card no. 4**
Relevant to the RFID reader version: This parameter indicates the no. of special card 4.
This parameter will only be active with an RFID card system.
- **P7 card no. 5**
Relevant to the RFID reader version: This parameter indicates the no. of special card 5.
This parameter will only be active with an RFID card system.

7.4.2.6 Menu 6 – network

This menu is only available for device control units with network connection (online version). This menu is only active with an RFID card system.

- **P1 register number**
These parameters indicate the register number.
- **P2-5 IP address**
These parameters indicate the IP address.
- **P6-9 subnet**
These parameters indicate the subnet.
- **P10-13 gateway**
This parameter indicates the gateway.

7.4.2.7 Menu 7 – device 1 to 4/8

The following parameters refer to the devices 1 to 4 or 8. "X" is used as wildcard in place of the device number.

- **P1 test run**
This parameter serves for the individual function test of programme X. By pressing the Plus key an energy amount of 0.3 kWh is credited to the account of device X. With every subsequent actuation the account is credited with another 0.3 kWh.
Pressing the Minus key aborts this process, the credit will be deleted and the port will be released again.
- **P2 register cash**
Indicates the amount of euros inserted as coins for booking device X since the least counter clearing.
This parameter is set back to 0 when reset is initiated in *Menu 1 – registers sum 1*.
- **P3 register card**
Indicates the amount of euros put to use for booking device X by means of RFID cards since the least counter clearing.
This parameter is set back to 0 when reset is initiated in *Menu 1 – registers sum 1*.
This parameter will only be active with an RFID card system.

- **P4 register tokens**
Indicates the amount of euros inserted as tokens for booking device X since the least counter clearing.
This parameter is set back to 0 when reset is initiated in *Menu 1 – tokens sum 1*.
- **P5 operating hours**
Indicates the number of operating hours of device X since the last counter clearing.
This parameter is set back to 0 when reset is initiated in *Menu 1 – uses sum 1*.
- **P6 operation**
By means of this parameter you set whether device X is to be in operation or not.
- **P7 standard price**
This parameter can only be adjusted if *Menu 4 - P3 unit price valid?* is set to "no".
The standard price is the minimum amount that has to be paid to book device X. If the customer pays more than this amount, more energy will be credited to him.
- **P9 time**
This parameter can only be adjusted if *Menu 4 - P3 unit price valid?* is set to "no".
Here the time for device X is defined (in min).
- **P11 maximum time**
This parameter can only be adjusted if *Menu 4 - P3 unit price valid?* is set to "no".
This parameter stipulates the maximum time that can be booked for device X through paying.
- **P12 paying extra**

7.4.3 Exemplary programming washing machine

Example for device1:

- 7-device1 => P6 operation = YES
- 7-device1 => P7 standard price = €0.50
- 7-device1 => P9 time = 1:00 min
- 7-device1 => P12 paying extra = YES

General settings:

- 4-operation => P1 operation = YES
- 4-operation => P3 standard price = NO
- 4-operation => P10 door openings = 3 x
- 4-operation => P10 door time = 10 sec
- 4-operation => P10 door blocking time = 1:00 min

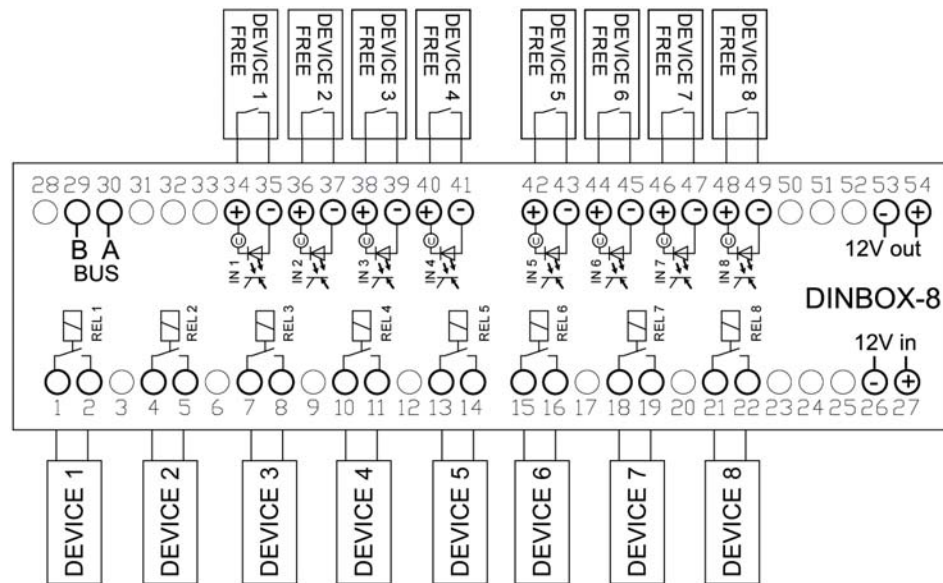

Fig. 7-9 Terminal assignment application of washing machine

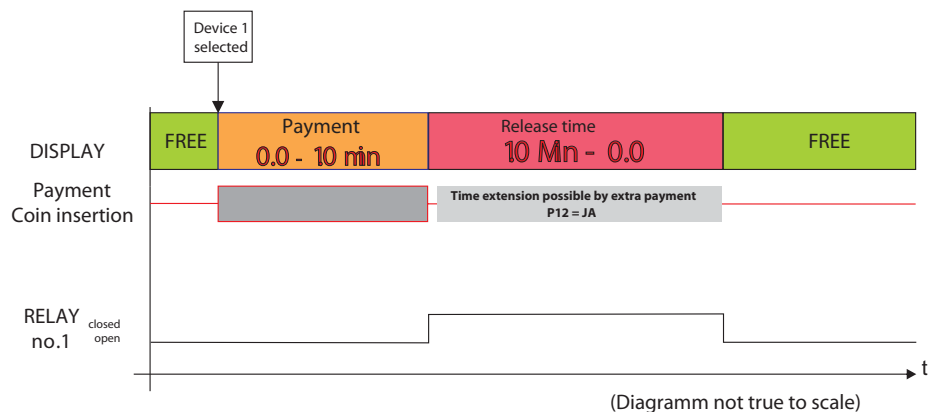

Fig. 7-10 Example 1: Standard time operation washing machine

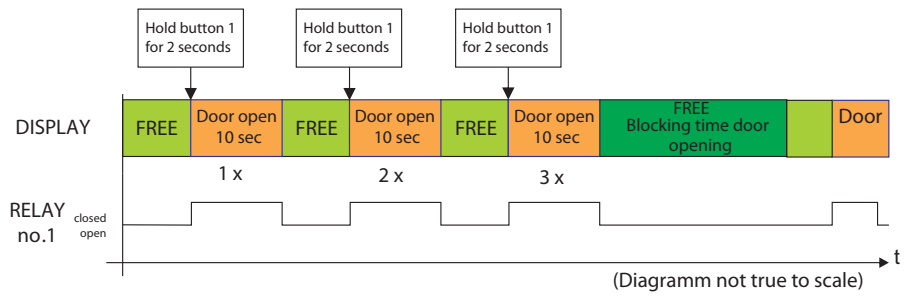

Fig. 7-11 Example 2: Door opening washing machine

7.5 Programming WC/washing machine

The following chapter describes the menu structure, parameters and exemplary programming for the application of a WC/washing machine.

7.5.1 Menu structure WC/washing machine

The menu structure is made up of seven superordinate menus. Each menu comes with parameters that can be set. Further information on the parameters are provided in chapter 7.5.2.

7.5.1.1 Menu 1 – counters total

The parameters shaded in grey are optional. These parameters will only be active with an RFID card system.

1 – counters total				
Parameter	P1	P2	P3	P4
Name	registers sum 1	registers sum 2	cards sum 1	cards sum 2
Function Plus key	-	-	-	-
Function Minus key	delete	-	delete	-
Default value	€0.00	€0.00	€0.00	€0.00
Parameter	P5	P6	P7	P8
Name	tokens sum 1	tokens sum 2	uses sum 1	uses sum 2
Function Plus key	-	-	-	-
Function Minus key	delete	-	delete	-
Default value	0	0	0	0

7.5.1.2 Menu 2 – prices and power

2 – prices and power		
Parameter	P1	P3
Name	standard price	time
Function Plus key	+ €0.10	+ 10 s
Function Minus key	- €0.10	- 10 s
Default value	€0.50	1:00 min

7.5.1.3 Menu 3 – clock & display

Parameter	P1	P2	P3	P4	P5
Name	hours	minutes	weekday	day	month
Function Plus key	+ 1 h	+ 1 min	+ 1 weekday	+ 1 day	+ 1 month
Function Minus key	- 1 h	- 1 min	- 1 weekday	- 1 day	- 1 month
Default value	-	-	-	-	-
Parameter	P6	P7	P8	P10	
Name	year	clock display	sum display	second display	
Function Plus key	+ 1 year	yes	yes	yes	
Function Minus key	- 1 year	no	no	no	
Default value	-	no	no	no	

7.5.1.4 Menu 4 – operation

The parameters shaded in grey are optional. These parameters will only be active with an RFID card system.

4 – operation				
Parameter	P1	P2	P3	P4
Name	operation	switch on everything	Unit price valid?	token value
Function Plus key	yes	yes	yes	+ €0.10
Function Minus key	no	no	no	- €0.10
Default value	yes	no	no	€1.00
Parameter	P5	P6	P7	P8
Name	adding token value to register	token reset	debiting step	pulse time
Function Plus key	yes	yes	+ €0.01	+1
Function Minus key	no	no	- €0.01	- 1
Default value	no	no	€1.00	5 s
Parameter	P9	P10	P11	
Name	maximum overpayment	basic setting	delete card no.	
Function Plus key	+ €0.01	yes	yes	
Function Minus key	- €0.01	-	-	
Default value	€1.00	-	-	

7.5.1.5 Menu 5 – information

The parameters shaded in grey are optional. These parameters will only be active with an RFID card system.

5 – information				
Parameter	P1	P2	P3	P4
Name	software version	serial number	card no. 1	card no. 2
Function Plus key	-	-	-	-
Function Minus key	-	-	-	-
Default value	-	-	-	-
Parameter	P5	P6	P7	
Name	card no. 3	card no. 4	card no. 5	
Function Plus key	-	-	-	
Function Minus key	-	-	-	
Default value	-	-	-	

7.5.1.6 Menu 6 – network

The parameters shaded in grey are optional. These parameters will only be active with an RFID card system.

6 – network				
Parameter	P1	P2 - P5	P6 - P9	P10 - P13
Name	register number	IP address	subnet	gateway
Function Plus key	+ 1	-	-	-
Function Minus key	- 1	-	-	-
Default value	200	-	-	-

7.5.1.7 Menu 7 – device 1 to 4/8

The parameters shaded in grey are optional. Parameter 3 will only be active with an RFID card system. Parameter 7 and 9 will only be available if *Menu 4 - P3 Unit price valid?* is set to "no".

7 – device 1 to 4/8					
Parameter	P1	P2	P3	P4	P5
Name	test run	register cash	register card	register tokens	number of uses
Function Plus key	+ 0.3 kWh	-	-	-	
Function Minus key	emergency stop	delete	delete	delete	delete
Default value	-	€0.00	€0.00	0	0
Parameter	P6	P7	P9	P11	P12
Name	operation	standard price	time	max.	paying extra
Function Plus key	yes	+ €0.10	+ 10 s	+ 1 min	yes
Function Minus key	no	- €0.10	- 10 s	- 1 min	no
Default value	yes	€0.50	1:00 min	4:00 h	yes

7.5.2 Parameters WC/washing machine

In this chapter the parameters of the menu structure are described in detail.
When a parameter is referred to, the systematic is as follows: "*menu number*" - "*parameter number*" "*parameter name*".

7.5.2.1 Menu 1 – counters total

- **P1 registers sum 1**
This parameter indicates the amount in euros inserted in the coin slot since the last counter clearing.
Pressing the Minus key sets the cash position back to €0.00.
- **P2 registers sum 2**
This parameter indicates the amount in euros inserted in the coin slot since the start-up.
This parameter cannot be reset.
- **P3 cards sum 1**
This parameter indicates the turnover in euros generated by means of RFID cards since the last counter clearing.
Pressing the Minus key sets the counter reading back to €0.00.
This parameter will only be active with an RFID card system.
- **P4 cards sum 2**
This parameter indicates the turnover in euros generated by means of RFID cards since the start-up.
This parameter cannot be reset.
This parameter will only be active with an RFID card system.
- **P5 tokens sum 1**
This parameter indicates the number of tokens inserted in the coin slot since the last counter clearing.
Pressing the Minus key sets the counter reading back to 0.
- **P6 tokens sum 2**
This parameter indicates the number of tokens inserted in the coin slot since the start-up.
This parameter cannot be reset.
- **P7 uses sum 1**
This parameter indicates the number of uses since the last counter clearing.
Pressing the Minus key sets the counter reading back to 0.
- **P8 uses sum 2**
This parameter indicates the number of uses since the start-up.
This parameter cannot be reset.

7.5.2.2 Menu 2 – prices and power

These settings can only be viewed when *Menu 4 – P3 – unit price* is activated.

- **P1 standard price**
The standard price is the minimum amount that has to be paid to book the selected port.
- **P2 time**
Here the time released for the sums set in *P1 (standard price)* is defined (in min).

7.5.2.3 Menu 3 – clock and display

- **P1 hours**
Here the current time is set (hours).
- **P2 minutes**
Here the current time is set (minutes).
- **P3 weekday**
Here the current weekday is set.
- **P4 day**
Here the current date is set.
- **P5 month**
Here the current month is set.
- **P6 year**
Here the current year is set.
- **P7 clock display**
With an activated clock display the time is displayed during operation of the tower.
- **P8 sum display**
With an activated sum display the sum is displayed during operation of the tower.
- **P11 second display**

7.5.2.4 Menu 4 – operation

- **P1 operation**
By means of this parameter you set whether the device control unit is to be in operation or not. When the device control unit is deactivated, booking is disabled. In that event inserted coins will be returned immediately.
- **P2 switch on everything**
When this parameter is active, all ports/terminal devices are enabled and can be used without paying (cleaning operation).
- **P3 unit price valid?**
If this parameter is set to "yes", the prices set in menu 2 apply for all the available ports at the device control unit.
If the parameter is set to "no", individual prices and energy amounts can be set in the respective programme menus starting from menu 7...
- **P4 token value**
This parameter defines the equivalent value of a token in euros. This value is used for booking according to the rate settings.
- **P5 adding token value to register**
If this parameter is activated, the set token value of each inserted token is added to the register.
- **P6 token reset**
If this parameter is set to "yes", the selected outlet will be released upon insertion of a token and the remaining credit will be deleted.
If this option is used, tokens will generally not be accepted as paying medium any more.
- **P7 debiting step**
This parameter will only be active with an RFID card system.
- **P8 pulse time**
- **P9 maximum overpayment**
- **P10 basic setting**
If this parameter is activated, the device control unit will be reset to the factory setting.
- **P11 delete card no.**
If this parameter is activated, the system's card number will be deleted, so that a new card number can be configured, e.g. when losing a system card. This parameter will only be active with an RFID card system.

7.5.2.5 Menu 5 – information

- **P1 software version**
This parameter indicates the installed software version.
- **P2 serial number**
This parameter indicates the individual serial number of the tower.
- **P3 card no. 1**
Relevant to the RFID reader version: This parameter indicates the no. of special card 1.
This parameter will only be active with an RFID card system.
- **P4 card no. 2**
Relevant to the RFID reader version: This parameter indicates the no. of special card 2.
This parameter will only be active with an RFID card system.
- **P5 card no. 3**
Relevant to the RFID reader version: This parameter indicates the no. of special card 3.
This parameter will only be active with an RFID card system.
- **P6 card no. 4**
Relevant to the RFID reader version: This parameter indicates the no. of special card 4.
This parameter will only be active with an RFID card system.
- **P7 card no. 5**
Relevant to the RFID reader version: This parameter indicates the no. of special card 5.
This parameter will only be active with an RFID card system.

7.5.2.6 Menu 6 – network

This menu is only available for device control units with network connection (online version). This menu is only active with an RFID card system.

- **P1 register number**
These parameters indicate the register number.
- **P2-5 IP address**
These parameters indicate the IP address.
- **P6-9 subnet**
These parameters indicate the subnet.
- **P10-13 gateway**
This parameter indicates the gateway.

7.5.2.7 Menu 7 – device 1 to 4/8

The following parameters refer to the devices 1 to 4 or 8. "X" is used as wildcard in place of the device number.

- **P1 test run**

This parameter serves for the individual function test of device X. By pressing the Plus key an energy amount of 0.3 kWh is credited to the account of device X. With every subsequent actuation the account is credited with another 0.3 kWh.

Pressing the Minus key aborts this process, the credit will be deleted and the port will be released again.

- **P2 register cash**

Indicates the amount of euros inserted as coins for booking device X since the last counter clearing.

This parameter is set back to 0 when reset is initiated in

Menu 1 – registers sum 1.

- **P3 register card**

Indicates the amount of euros put to use for booking device X by means of RFID cards since the last counter clearing.

This parameter is set back to 0 when reset is initiated in

Menu 1 – registers sum 1.

This parameter will only be active with an RFID card system.

- **P4 register tokens**

Indicates the amount of euros inserted as tokens for booking device X since the last counter clearing.

This parameter is set back to 0 when reset is initiated in

Menu 1 – tokens sum 1.

- **P5 operating hours**

Indicates the number of operating hours of device X since the last counter clearing.

This parameter is set back to 0 when reset is initiated in

Menu 1 – uses sum 1.

- **P6 operation**

By means of this parameter you set whether device X is to be in operation or not.

- **P7 standard price**

This parameter can only be adjusted if *Menu 4 - P3 unit price valid?* is set to "no".

The standard price is the minimum amount that has to be paid to book device X. If the customer pays more than this amount, more energy will be credited to him.

- P9 time**
 This parameter can only be adjusted if *Menu 4 - P3 unit price valid?* is set to "no".
 This parameter stipulates the maximum time that can be booked for device X through paying.

7.5.3 Exemplary programming WC/washing machine

Example for device1:

- 7-device1 => P6 operation = YES
- 7-device1 => P7 standard price = €0.50
- 7-device1 => P9 time = 1:00 min

General settings:

- 4-operation => P1 operation = YES
- 4-operation => P3 standard price = NO
- 4-operation => P9 max. overpayment = €0.50

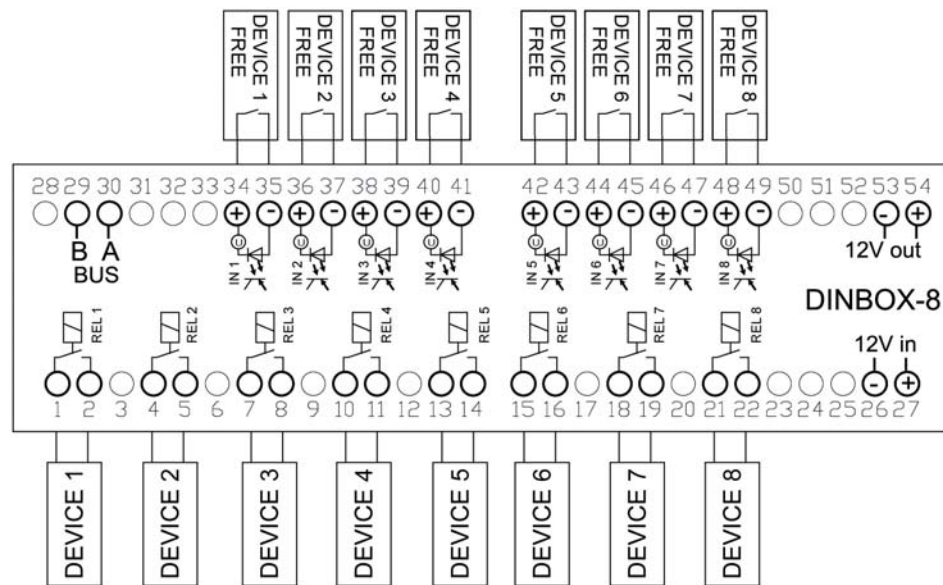

Fig. 7-12 Port assignment application of WC/washing machine

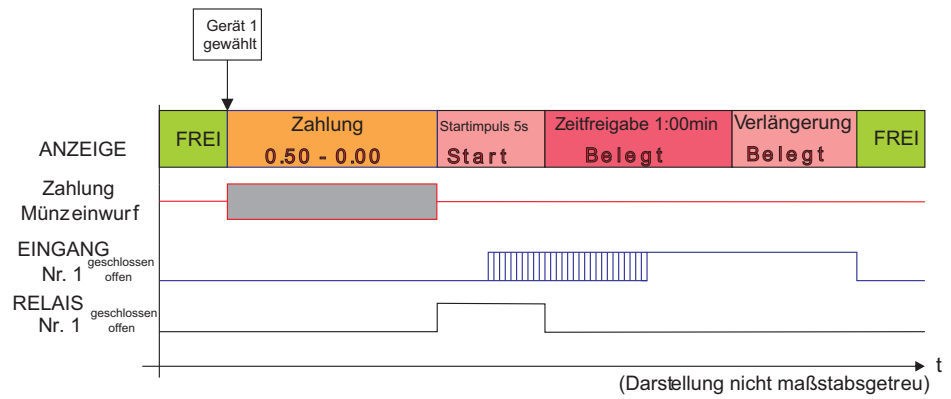

Fig. 7-13 Example 1, pulse mode: 4-operation => P8 pulse time = 5 s

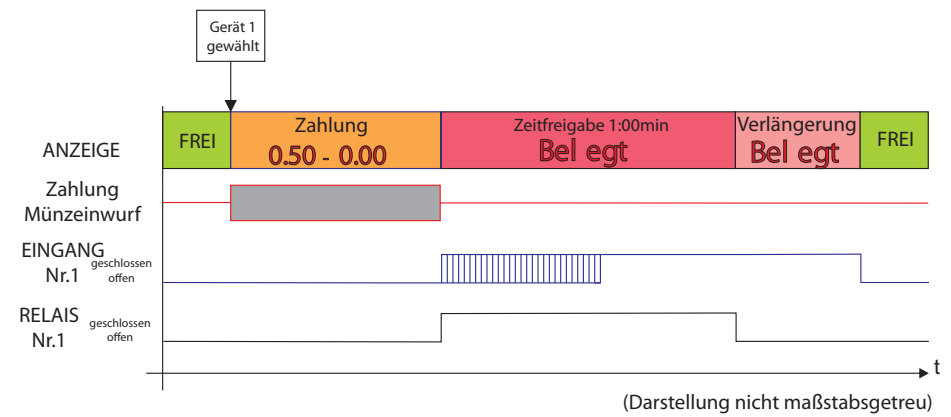

Fig. 7-14 Example 2, time mode: 4-operation => P8 pulse time = 0 s

7.6 Programming a charging station

The following chapter describes the menu structure, parameters and exemplary programming for the application of a charging station for electric cars.

7.6.1 Menu structure charging station

The menu structure is made up of seven superordinate menus. Each menu comes with parameters that can be set. Further information on the parameters are provided in chapter 7.6.2.

7.6.1.1 Menu 1 – counters total

The parameters shaded in grey are optional. These parameters will only be active with an RFID card system.

1 – counters total				
Parameter	P1	P2	P3	P4
Name	registers sum 1	registers sum 2	cards sum 1	cards sum 2
Function Plus key	-	-	-	-
Function Minus key	delete	-	delete	-
Default value	€0.00	€0.00	€0.00	€0.00
Parameter	P5	P6	P7	P8
Name	tokens sum 1	tokens sum 2	operating time sum 1	operating time sum 2
Function Plus key	-	-	-	-
Function Minus key	delete	-	delete	-
Default value	0	0	0	0

7.6.1.2 Menu 2 – prices and power

2 – prices and power			
Parameter	P1	P3	P4
Name	standard price	time	maximum time
Function Plus key	+ €0.10	+ 10 s	+ 1 min
Function Minus key	- €0.10	- 10 s	- 1 min
Default value	€0.50	1:00 min	4:00 h

7.6.1.3 Menu 3 – clock & display

Parameter	P1	P2	P3	P4	P5
Name	hours	minutes	weekday	day	month
Function Plus key	+ 1 h	+ 1 min	+ 1 weekday	+ 1 day	+ 1 month
Function Minus key	- 1 h	- 1 min	- 1 weekday	- 1 day	- 1 month
Default value	-	-	-	-	-
Parameter	P6	P7	P8	P10	
Name	year	clock display	sum display	second display	
Function Plus key	+ 1 year	yes	yes	yes	
Function Minus key	- 1 year	no	no	no	
Default value	-	no	no	no	

7.6.1.4 Menu 4 – operation

The parameters shaded in grey are optional. These parameters will only be active with an RFID card system.

4 – operation					
Parameter	P1	P2	P3	P4	P5
Name	operation	Switch on everything	unit price valid?	token value	adding token value to register
Function Plus key	yes	yes	yes	+ €0.10	yes
Function Minus key	no	no	no	- €0.10	no
Default value	yes	no	no	€1.00	no
Parameter	P6	P7	P13	P14	
Name	token reset	debiting step	basic setting	card no. delete	
Function Plus key	yes	+ €0.01	yes	yes	
Function Minus key	no	- €0.01	-	-	
Default value	no	€1.00	-	-	

7.6.1.5 Menu 5 – information

The parameters shaded in grey are optional. These parameters will only be active with an RFID card system.

5 – information				
Parameter	P1	P2	P3	P4
Name	software version	serial number	card no. 1	card no. 2
Function Plus key	-	-	-	-
Function Minus key	-	-	-	-
Default value	-	-	-	-
Parameter	P5	P6	P7	
Name	card no. 3	card no. 4	card no. 5	
Function Plus key	-	-	-	
Function Minus key	-	-	-	
Default value	-	-	-	

7.6.1.6 Menu 6 – network

The parameters shaded in grey are optional. These parameters will only be active with an RFID card system.

6 – network				
Parameter	P1	P2 - P5	P6 - P9	P10 - P13
Name	register number	IP address	subnet	gateway
Function Plus key	+ 1	-	-	-
Function Minus key	- 1	-	-	-
Default value	200	-	-	-

7.6.1.7 Menu 7 – plugs 1a, 1b, 2a, 2b, 3a, 3b, 4a, 4b

The parameters shaded in grey are optional. Parameter 3 will only be active with an RFID card system. Parameter 7 and 9 will only be available if *Menu 4 - P3 unit price valid?* is set to "no".

7 – device 1 to 4/8					
Parameter	P1	P2	P3	P4	P5
Name	test run	register cash	register card	register tokens	operating hours
Function Plus key	+ 0.3 kWh	-	-	-	
Function Minus key	emergency stop	delete	delete	delete	delete
Default value	-	€0.00	€0.00	0	0 Wh
Parameter	P6	P7	P9		
Name	operation	standard price	time		
Function Plus key	yes	+ €0.10	+ 10 s		
Function Minus key	no	- €0.10	- 10 s		
Default value	yes	€0.50	1:00 min		

7.6.2 Parameters charging station

In this chapter the parameters of the menu structure are described in detail. When a parameter is referred to, the systematic is as follows: "*menu number*" - "*parameter number*" "*parameter name*".

7.6.2.1 Menu 1 – counters total

- **P1 registers sum 1**
This parameter indicates the amount in euros inserted in the coin slot since the last counter clearing.
Pressing the Minus key sets the cash position back to €0.00.
- **P2 registers sum 2**
This parameter indicates the amount in euros inserted in the coin slot since the start-up.
This parameter cannot be reset.
- **P3 cards sum 1**
This parameter indicates the turnover in euros generated by means of RFID cards since the last counter clearing.
Pressing the Minus key sets the counter reading back to €0.00.
This parameter will only be active with an RFID card system.
- **P4 cards sum 2**
This parameter indicates the turnover in euros generated by means of RFID cards since the start-up.
This parameter cannot be reset.
This parameter will only be active with an RFID card system.
- **P5 tokens sum 1**
This parameter indicates the number of tokens inserted in the coin slot since the last counter clearing.
Pressing the Minus key sets the counter reading back to 0.
- **P6 tokens sum 2**
This parameter indicates the number of tokens inserted in the coin slot since the start-up.
This parameter cannot be reset.
- **P7 operating time sum 1**
This parameter indicates the operating time since the last counter clearing.
Pressing the Minus key sets the counter reading back to 0.
- **P8 operating time sum 2**
This parameter indicates the operating time since the start-up.
This parameter cannot be reset.

7.6.2.2 Menu 2 – prices and power

These settings can only be viewed when *Menu 4 – P3 – unit price* is activated.

- **P1 standard price**
The standard price is the minimum amount that has to be paid to book the selected port.
- **P2 time**
Here the time released for the sums set in *P1 (standard price)* is defined (in min).
- **P3 maximum time**
This parameter stipulates the maximum time that can be booked through paying.

7.6.2.3 Menu 3 – clock and display

- **P1 hours**
Here the current time is set (hours).
- **P2 minutes**
Here the current time is set (minutes).
- **P3 weekday**
Here the current weekday is set.
- **P4 day**
Here the current date is set.
- **P5 month**
Here the current month is set.
- **P6 year**
Here the current year is set.
- **P7 clock display**
With an activated clock display the time is displayed during operation of the tower.
- **P8 sum display**
With an activated sum display the sum is displayed during operation of the tower.
- **P11 second display**

7.6.2.4 Menu 4 – operation

- **P1 operation**

By means of this parameter you set whether the device control unit is to be in operation or not. When the device control unit is deactivated, booking is disabled. In that event inserted coins will be returned immediately.
- **P2 switch on everything**

When this parameter is active, all ports/terminal devices are enabled and can be used without paying (cleaning operation).
- **P3 unit price valid?**

If this parameter is set to "yes", the prices set in menu 2 apply for all the available ports at the device control unit.
If the parameter is set to "no", individual prices and energy amounts can be set in the respective programme menus starting from menu 7...
- **P4 token value**

This parameter defines the equivalent value of a token in euros. This value is used for booking according to the rate settings.
- **P5 adding token value to register**

If this parameter is activated, the set token value of each inserted token is added to the register.
- **P6 token reset**

If this parameter is set to "yes", the selected outlet will be released upon insertion of a token and the remaining amount of energy will be deleted. The so far available credit balance expires. If this option is used, tokens will generally not be accepted as paying medium any more.
- **P7 debiting step**

This parameter will only be active with an RFID card system.
- **P13 basic setting**

If this parameter is activated, the device control unit will be reset to the factory setting.
- **P14 delete card no.**

If this parameter is activated, the system's card number will be deleted, so that a new card number can be configured, e.g. when losing a system card. This parameter will only be active with an RFID card system.

7.6.2.5 Menu 5 – information

- **P1 software version**
This parameter indicates the installed software version.
- **P2 serial number**
This parameter indicates the individual serial number of the tower.
- **P3 card no. 1**
Relevant to the RFID reader version: This parameter indicates the no. of special card 1.
This parameter will only be active with an RFID card system.
- **P4 card no. 2**
Relevant to the RFID reader version: This parameter indicates the no. of special card 2.
This parameter will only be active with an RFID card system.
- **P5 card no. 3**
Relevant to the RFID reader version: This parameter indicates the no. of special card 3.
This parameter will only be active with an RFID card system.
- **P6 card no. 4**
Relevant to the RFID reader version: This parameter indicates the no. of special card 4.
This parameter will only be active with an RFID card system.
- **P7 card no. 5**
Relevant to the RFID reader version: This parameter indicates the no. of special card 5.
This parameter will only be active with an RFID card system.

7.6.2.6 Menu 6 – network

This menu is only available for device control units with network connection (online version). This menu is only active with an RFID card system.

- **P1 register number**
These parameters indicate the register number.
- **P2-5 IP address**
These parameters indicate the IP address.
- **P6-9 subnet**
These parameters indicate the subnet.
- **P10-13 gateway**
This parameter indicates the gateway.

7.6.2.7 Menu 7 – plugs 1a, 1b, 2a, 2b, 3a, 3b, 4a, 4b

The following parameters refer to plugs 1a, 1b, 2a, 2b, 3a, 3b, 4a, 4b. "X" is used as wildcard in place of the plug number.

- **P1 test run**
This parameter serves for the individual function test of plug X. By pressing the Plus key an energy amount of 0.3 kWh is credited to the account of plug X. With every subsequent actuation the account is credited with another 0.3 kWh.
Pressing the Minus key aborts this process, the credit will be deleted and the port will be released again.
- **P2 register cash**
Indicates the amount of euros inserted as coins for booking plug X since the least counter clearing.
This parameter is set back to 0 when reset is initiated in *Menu 1 – registers sum 1*.
- **P3 register card**
Indicates the amount of euros put to use for booking plug X by means of RFID cards since the least counter clearing.
This parameter is set back to 0 when reset is initiated in *Menu 1 – registers sum 1*.
This parameter will only be active with an RFID card system.
- **P4 register tokens**
Indicates the amount of euros inserted as tokens for booking plug X since the least counter clearing.
This parameter is set back to 0 when reset is initiated in *Menu 1 – tokens sum 1*.

- **P5 operating hours**

Indicates the number of operating hours of plug X since the last counter clearing.

This parameter is set back to 0 when reset is initiated in *Menu 1 – uses sum 1*.
- **P6 operation**

By means of this parameter you set whether plug X is to be in operation or not.
- **P7 standard price**

This parameter can only be adjusted if *Menu 4 - P3 unit price valid?* is set to "no".

The standard price is the minimum amount that has to be paid to book plug X. If the customer pays more than this amount, more energy will be credited to him.
- **P9 time**

This parameter can only be adjusted if *Menu 4 - P3 unit price valid?* is set to "no".

This parameter stipulates the maximum time that can be booked for plug X through paying.

7.6.3 Exemplary programming charging station

"Free" signal

If the socket is free/ready for operation, the input must be inactive, i. e. the contact must be open. It is then possible to make a selection and payment for the socket on the machine.

If the contact is closed, it is not possible to make a selection or payment. As long as the plug is connected and charging is in progress, the contact must be closed.

Output start signal potential-free

After paying for a socket LP, the respective contact is activated for the paid period of time and both corresponding charging mode buttons (2.2 and 3.7 kWh) are blocked.

End 1: regular expiry of the paid period of time.

End 2: change of input signal due to early pulling of plug.

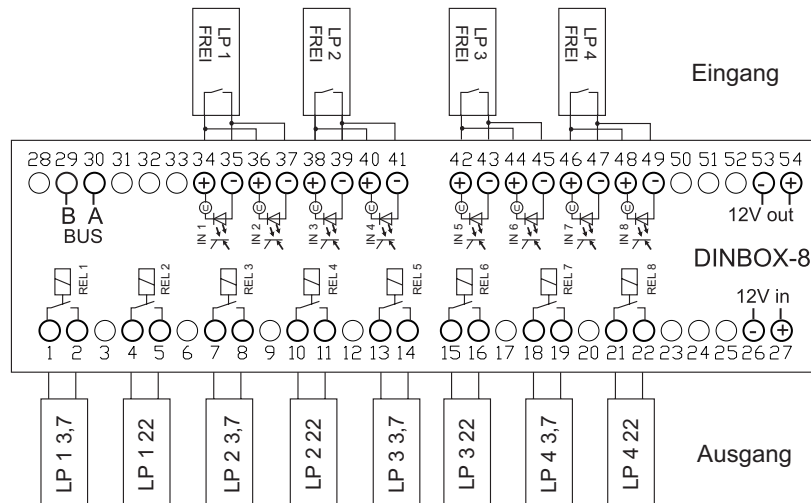

Fig. 7-15 Terminal assignment for the application of a charging station

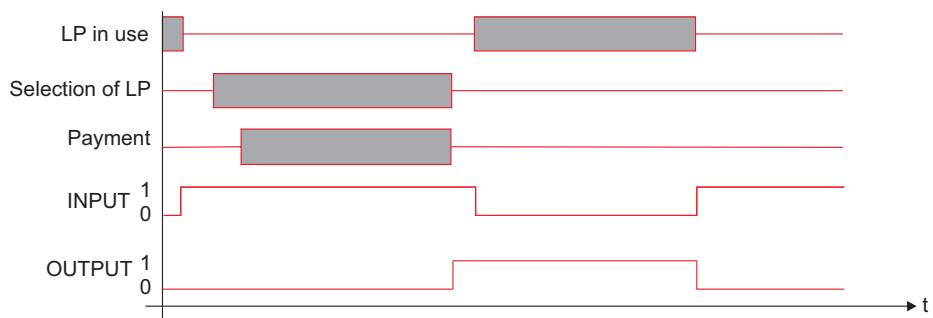

Fig. 7-16 Diagram time course for the application of a charging station

8 Maintenance

Anyone charged with maintenance tasks must have read and understood this operating manual, especially the safety chapter.

For information on which maintenance tasks are required please see chapter 8.2, page 8-2.

If questions arise please contact your specialist dealer or Beckmann GmbH.

For work at the electrical installation consult an electrically skilled person.

8.1 Safety

Take the device control unit out of operation before starting maintenance, see chapter 6.3, page 6-10.

**Danger!**

Risk of death due to electrical voltage!

The energy tower must be de-energized before undertaking any work.

Shut the energy tower down, see chapter 6.3, page 6-10 and consult an electrically skilled person!

**Warning!**

Danger of minor injuries due to sharp edges or falling objects!

Wear your personal protective equipment.

**Caution!**

Property damage owing to the use of wrong cleaning agents.

Only use the cleaning agents specified in chapter 8.3.1 to clean the tower!

Never use a high-pressure cleaner to clean the tower!

8.2 Maintenance schedule

Tab. 8-1 Maintenance intervals

Component	Maintenance activity	Maintenance interval				Further information
		daily	weekly	monthly	annually	
housing	visual inspection for damage	X				
	Cleaning					in case of heavy contamination, e.g. when the display is no longer legible Do not use a high-pressure cleaner. Do not use any aggressive cleaning agents. Use cleaning agents especially suited for stainless steel.
coin validator	cleaning coin slot				X	as needed, see supplier instructions in chapter 11.3.1, page 11-7

8.3 Maintenance activities

8.3.1 Cleaning the housing

Clean the housing by means of a damp, soft, lint-free cloth. Only use clear water and, if required, a cleaning agent suitable for stainless steel.

Ensure that no moisture can enter. Do not use any solvents, alcohol-based cleaning agents or abrasive cleaners. Do not use a high-pressure cleaner.

Observe the maintenance instructions for stainless steel in chapter 11.2, page 11-5.

8.3.2 Cleaning the coin validator

1. Open the lock (30) at the front of the device control unit.

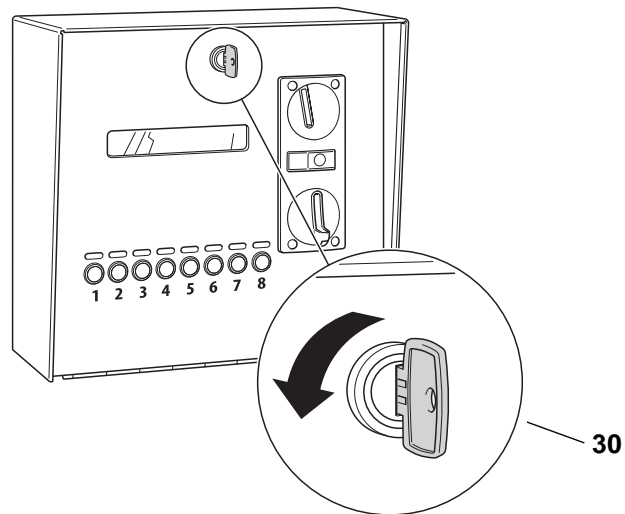

Fig. 8-1 Opening lock

2. Open the hinged cover.

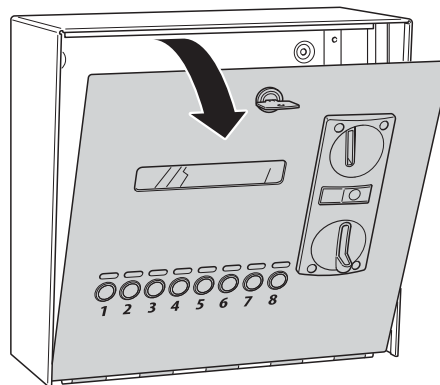

Fig. 8-2 Opening hinged cover.

3. Remove and clean the coin validator. For information on how to proceed, please see the supplier instructions in chapter 11.3.1, page 11-7.
4. After cleaning, close the cover again.
5. Use the key to lock it.

9 Faults

Anyone charged with the task of troubleshooting must have read and understood this operating manual, especially the safety chapter.

Rectify faults immediately to prevent further damage.

Information on how to identify and clear the fault is provided in the fault table on chapter 9.2, page 9-2 as well as in the supplied external operating manuals.

If questions arise please contact your specialist dealer or Beckmann GmbH.

In case of faults at the electrical installation, consult an electrically skilled person.

9.1 Safety

Take the energy tower out of operation before performing troubleshooting, see chapter 6.3, page 6-10.

**Danger!**

Risk of death due to electrical voltage!

The energy tower must be de-energized before undertaking any work.

Shut the energy tower down, see chapter 6.3, page 6-10 and consult an electrically skilled person!

**Warning!**

Danger of minor injuries due to sharp edges or falling objects!

Wear your personal protective equipment.

**Caution!**

Property damage owing to the use of wrong cleaning agents!

Only use the cleaning agents specified in the maintenance chapter to clean the tower!

Never use a high-pressure cleaner to clean the tower!

9.2 Fault table

The following tables lists a number of faults which can occur during operation and may be rectified by yourself.

If you are not able to clear the fault, immediately notify your specialist dealer or Beckmann GmbH.

Tab. 9-1 Faults

Fault	Cause	Remedial measure
LED is not illuminated in spite of the corresponding output/input being in use or free.	Defective LED	Have the defective LED checked by a qualified electrician and replaced, if required.
Coin cannot be inserted.	Coin validator blocked by foreign object	Clean the coin validator, see chapter 8.3.2, page 8-3.
Coin is not recognized	Coin is not programmed	Check the programming of the coin validator, see supplier instructions in chapter 11.3.1, page 11-7.
	Dirty coin validator	Clean the coin validator, see chapter 8.3.2, page 8-3.
	Defective coin validator	If after cleaning the coin validator still does not function, have it checked by a qualified electrician and replaced, if required.

10 Disposal

Disassemble the device control unit for disposal and separate it into the individual material groups:

- plastics
- non-ferrous metals (e. g. copper scrap)
- aluminium
- electronic scrap
- steel

Dispose of the materials according to the national regulations.

11 Annex

11.1 Declaration of Conformity

in accordance with the EC Low Voltage Directive 2006/95/EC, Annex III, Section B

Herewith we declare that the following energy tower has been declared in conformity with the EC Low Voltage Directive 2006/95/EC.

Description of the electrical equipment:	Energy tower EMS-ENERGY
Year of manufacture:	as of 2014
Relevant EC directives:	Low Voltage Directive 2006/95/EC as of 12 December 2006
	Directive 2004/108/EC on electromagnetic compatibility as of 15 December 2004
Applied harmonised standards:	
Other applied technical standards and specifications:	Safety standards: DIN EN 61010-1:2011-07 EMC standards: DIN EN 61326-1:2013-06
Manufacturer:	Beckmann GmbH Brandtstr. 1 33161 Hövelhof Germany

Place, date: Hövelhof, 01 September 2014

Signature: _____

Identification of signer: Jürgen Beckmann, Managing Director

11.2 Stainless steel cleaning and maintenance instructions



Beckmann GmbH
Brandtstraße 1
D-33161 Hövelhof
Fon +49 (0) 52 57-98 23-0
Fax +49 (0) 52 57-98 23-11
info@beckmann-gmbh.de
www.beckmann-gmbh.de
Amtsgericht Paderborn, HRB 6380
Geschäftsführer Jürgen Beckmann

Edelstahl Reinigungs- und Pflegeanleitung

Werkstoff Edelstahl

ist eine besonders korrosionsbeständige Stahllegierung, die unter bestimmten Umfeld- und Pflegebedingungen blank und „rostfrei“ bleibt.

Unsere Standardproduktausführung ist aus V2A, aus dem Werkstoff 1.4301.

Dieser Werkstoff ist für den Einsatz im Außenbereich bei normaler Außenatmosphäre geeignet.

Bei **Einsatz in aggressiven Umgebungsbedingungen**, darunter fällt beispielsweise Seewasseratmosphäre und bei in der Luft enthaltener, schwefeliger Säure, bieten wir unsere Produkte auch in gepulverter Ausführung an.

Salzstreuen gegen Eisbildung ist im unmittelbaren Bereich von Edelstahlbauteilen zu unterlassen.

Pflege und Vorkehrungen bei der Installation des Produktes

Stahl-Schleifstaub ist der Tod jeder Edelstahloberfläche. Arbeiten mit der Trennscheibe bei der Montage der Säulen oder bei benachbarten Gewerken, führt zwangsläufig zu punktförmigen Korrosionsstellen (Fremdrost, Lochkorrosion) an den Oberflächen.

Reinigung nach der Installation: Das Produkt wird im Auslieferungszustand mit einem Edelstahlpflegemittel versiegelt. Bei geringen Verunreinigungen durch die Montage, ist es am besten, den Staub mit einem trockenen, sauberen Tuch zu entfernen.

Bei Reinigung mit einem Fettlöser – warmes Wasser mit Geschirrspülmittel (kein Glasreiniger) – ist danach die getrocknete Oberfläche zwingend mit einem Edelstahlpflegemittel zu versiegeln. Besonders frisch geschliffene Oberflächen benötigen einige Zeit zur Ausbildung einer Schutzschicht „Passivschicht“; daher ist gerade der Oberflächenschutz bei neuen Produkten wesentlich.

11.3 Supplier documentation

11.3.1 EMP coin validator

11.3.1.1 Coin validator settings

Bedienungsanleitung | Energiesäule | Beckmann GmbH

- **P9 Aus mit WM**

Ist dieser Parameter aktiviert, wird bei Einwurf einer Wertmarke der gewählte Ausgang freigegeben und die Restenergiemenge wird gelöscht. Wenn diese Option genutzt wird, können Wertmarken grundsätzlich nicht mehr zum Bezahlen genutzt werden.

7 Der elektronische Münzprüfer

Abbildung 2 :Der elektronische Münzprüfer (WH)

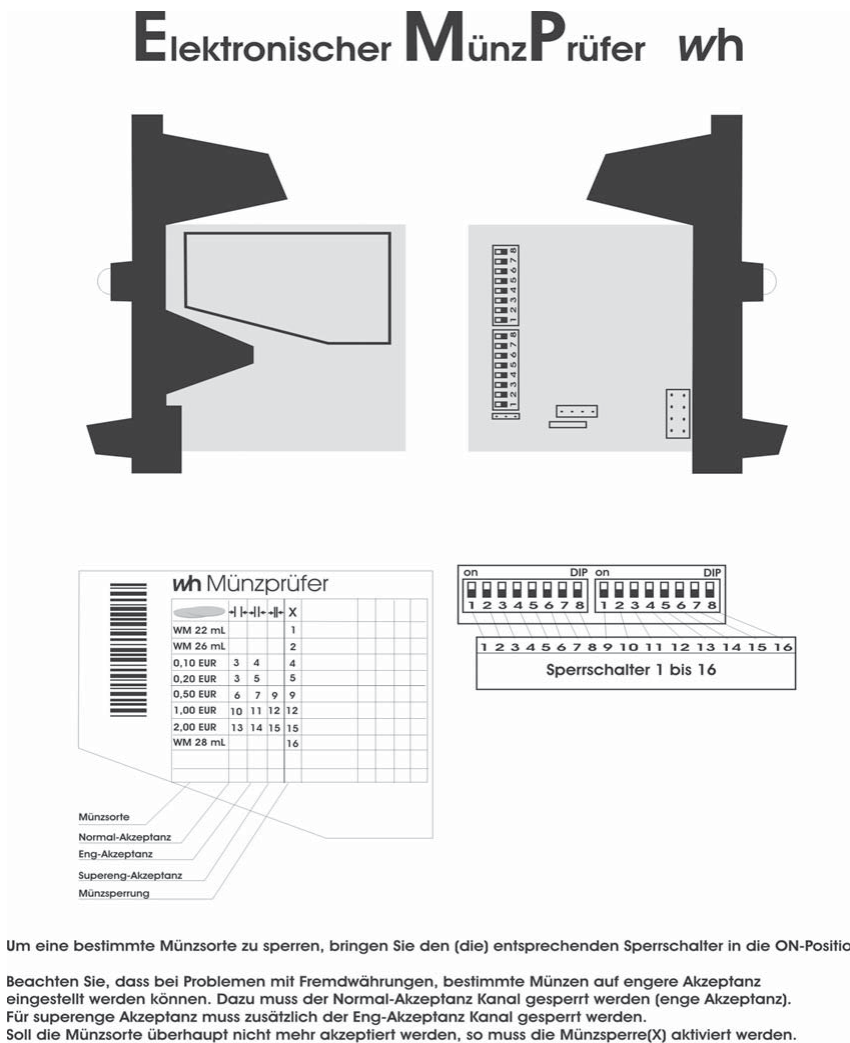

7.1 Programmieren der Münzkanäle des EMP

Die elektronischen Münzprüfer (EMP) von wh sind werksseitig auf die in der Tabelle 9 angegebenen Münzen in unterschiedlichen Toleranzen programmiert. Jede dieser Münzen kann durch Setzen eines Sperrschalters separat verriegelt werden.

Die nachfolgende Tabelle zeigt die Belegung der Kanäle der EURO EMP - Version.

Münzart EURO	Bezeichnung (normal)	Bezeichnung (eng)	Bezeichnung (extra eng)	Sperrschalter
WM 22mm mit Loch	1	-	-	1 links
WM 26mm mit Loch	2	-	-	2 links
10 Cent normal	3	4	-	4 links
20 Cent normal	3	5	-	5 links
50 Cent normal	6	7	9	1 rechts
1 EURO	10	11	12	4 rechts
2 EURO	13	14	15	7 rechts
WM 28mm mit Loch	16			8 rechts

Tabelle 1 :Belegung der Münzkanäle

Bei der Einstellung des EMP ist folgendes zu beachten:

- Sperrschalter auf ON (nach oben) sperrt den entsprechenden Kanal, Sperrschalter auf OFF (nach unten) gibt den entsprechenden Kanal frei.
- Die Münzen können teilweise in verschiedenen Stufen freigeschaltet werden, wobei bedeuten:
 - **normal:** Der EMP prüft die Münzen in normalen Toleranzbereichen. Diese Einstellung ist werksseitig eingestellt.
 - **Eng:** Die Toleranzbereiche werden eingeengt. Dadurch können Falschmünzen besser aussortiert werden. Die Akzeptanz für die eingestellte Münzart geht leicht zurück. Um eine Münze "eng" zu prüfen, muß der Sperrschalter "normal" für diese Münzart auf ON stehen.
 - **Supereng:** Weiter verbessertes Erkennen von Falschmünzen. Die Akzeptanz für die engestellte Münzart geht weiter zurück. Die Sperrschalter "normal" und "eng" müssen auf ON stehen.
- Nach Umstellen eines Schalters muss die Energiesäule aus- und wieder eingeschaltet werden, um die neuen Einstellungen zu aktivieren.

Es ist darauf zu achten, dass der freie Fall der Münzen aus dem EMP nicht behindert wird (z.B. durch eine zu volle Münzbox), da sonst eine einwandfreie Münzerkennung nicht gewährleistet ist, und durchfallende Münzen nicht gewertet werden können.

11.3.1.2 EMP coin validator, label, maintenance, troubleshooting

Technisches Manual EMP 8x0.00/04/13/17 v7

wh Münzprüfer Berlin GmbH, Germany

5. Münzprüfer-Label

Auf dem Label des Münzprüfers sind alle notwendigen Angaben zu den Münzen, den Ausgängen und den Sperrschaltern enthalten. Im einzelnen sind folgende Informationen dem Label zu entnehmen:



Abb. 17 Beispiel eines EMP 800 v7 Labels

Oben in der Mitte steht die vollständige Typenbezeichnung des Münzprüfers:

EMP 800.00 v7

Am Ende der gleichen Zeile sind alle Optionen durch einen „/“-Strich getrennt aufgeführt, im Beispiellabel:

/E erweiterter Temperatur- und Feuchtigkeitsbereich

Links neben dem Barcode (90° gedreht), ist die Seriennummer, die Herstellungswoche und das Herstellungsjahr zu finden. Die gleichen Angaben enthält auch der Barcode. Ganz links außen ist die Nummer der Liefervorschrift, mit der das Gerät im Werk programmiert wurde, aufgedruckt.

Alle weiteren Angaben beziehen sich auf die programmierten Münzen, welche in Form einer Tabelle dargestellt sind. Die einzelnen Spalten haben folgende Bedeutung:



Münzsorte (Wert und Währung)

Teachmode Kanäle werden mit TKn gekennzeichnet. Das „n“ steht für die Nummer des Sperrschalters, mit dem der Teachmode für diesen Kanal aktiviert wird.



Sperrschalter für den weiten Kanal



Sperrschalter für den mittleren Kanal



Sperrschalter für den engen Kanal



Sperrschalter für eine Münze oder Münzgruppe (ggf. eine Währung)



Ausgangsleitung

Für den EMP 8x0.00 v7 werden die Ausgangsleitungen (1 bis 6) direkt angegeben. Beim EMP 8x0.04 v7 mit binär codierten Ausgängen, erfolgt die Angabe in hexadezimaler Form (Zum Beispiel ist bei 2,- € der Eintrag „0E“ zu finden. Dieser entspricht dem Binärcode 001110, also werden bei 2,- € die Ausgangsleitungen 2, 3 und 4 aktiviert).

6. **Wartung**

6.1. **Reinigung**

Der EMP 800 v7 ist ein sehr robuster Münzprüfer und arbeitet im Wesentlichen wartungsfrei. Bei starker Beanspruchung oder bei Betrieb an Orten mit hoher Luftverunreinigung, wie z.B. durch Staub, Reinigungsmitteln, Chemikalien, Nikotin etc. sollte der Münzprüfer in regelmäßigen Abständen gereinigt werden. Die erforderlichen Intervalle hängen sehr stark von den jeweiligen Einsatzbedingungen ab.

Bei einer mittleren Umweltbelastung und mechanischen Beanspruchung genügt es, den Münzprüfer einmal pro Jahr bei geöffneter Klappe innen mit einem weichen, mit einer alkoholischen Flüssigkeit getränkten Lappen auszuwischen. Es kann auch lauwarmes Wasser mit etwas Spülmittel verwendet werden. Es ist unbedingt darauf zu achten, dass bei der Reinigung kein Schmutz in die Bohrungen des optischen Messsystems eingetragen wird. Die Lichtschranken am Münzaustritt sollten mit einem weichen Pinsel gereinigt oder mit Druckluft ausgeblasen werden.



Stellen Sie sicher, dass der Münzprüfer während der Reinigung stromlos ist.

Achten Sie darauf, dass das Tuch feucht, nicht nass ist. Es darf keinesfalls Flüssigkeit in das Gerät laufen.



Vermeiden Sie Lösungs- oder Scheuermittel die den Kunststoff angreifen können.

Verwenden Sie niemals einem öligen Lappen! Ölen Sie niemals den Weichenmagneten, Scharniere etc.!

6.2. **Beseitigung von Störungen**

Nicht jede Funktionsstörung muss ihre Ursache in einem Defekt des Münzprüfers haben. Die Ursachen liegen oftmals auch in beschädigten oder losen Anschlussleitungen, falschen Einstellungen oder einer zu schwachen Stromversorgung.

Die nachfolgende Tabelle gibt Ihnen einen Überblick über die häufigsten Fehlerursachen. Prüfen Sie daher bitte zuerst an Hand der nachfolgenden Tabelle, ob Sie die Störung nicht ganz einfach selbst beseitigen können.

Fehlerbild	mögliche Ursachen	Fehlerbeseitigung
Münzprüfer nimmt Münze nicht an	keine Versorgungsspannung	<ul style="list-style-type: none"> • Automat mit Spannung versorgen, prüfen ob das Netzteil auch wirklich Spannung liefert • Zustand des Kabels kontrollieren, Kabel richtig am Münzprüfer und Automaten anschließen
	Versorgungsspannung zu schwach	<ul style="list-style-type: none"> • Wenn das Netzteil unterdimensioniert ist, kann es zum Zusammenbrechen der Stromversorgung kommen, wenn der Weichenmagnet anzieht und damit der kurzzeitige Stromverbrauch des Münzprüfers stark ansteigt. Stellen Sie sicher, dass bei einer Last von 400 mA die Versorgungsspannung nicht unter 8 Volt zusammenbricht!
	Münze gesperrt	<ul style="list-style-type: none"> • Prüfen ob die Münzen nicht über die Sperrschalter gesperrt sind • Sicherstellen, dass der Münzprüfer nicht über das Signal „Generalsperre“ (Pin 6) durch den Automaten gesperrt ist. • Sicherstellen, dass Pin 5 (Rückgabesignal) nicht durch den Automaten auf Masse gezogen wird.
	Münzprüfer verschmutzt	<ul style="list-style-type: none"> • Münzprüfer reinigen
	Rückgabehebel bzw. Rückgabebetaste klemmt	<ul style="list-style-type: none"> • Sicherstellen, dass der Rückgabehebel bzw. die Rückgabebetaste nicht dauerhaft betätigt ist. Die Rückgabebetätigung wird mit einem Mikroschalter detektiert (Ausnahme Option/P) und dem Münzprüfer gemeldet. Dieser nimmt so lange keine Münzen an, wie das Rückgabesignal anliegt. Der Mikroschalter wird bereits betätigt, bevor sich die Klappe beginnt zu öffnen!
	Lichtschanke im Münzaustritt verschmutzt oder durch einen Gegenstand blockiert	<ul style="list-style-type: none"> • Lichtschanke reinigen • Fremdkörper im Münzaustritt entfernen

Münzprüfer nimmt Münze an, gibt aber kein Kassiersignal aus	Münzaustritt wird behindert, so dass sich die Münze zu lange in der Lichtschranke befindet oder nach dem Austritt aus der Lichtschranke wieder in ihren Bereich zurückspringt	<ul style="list-style-type: none">Sicherstellen, dass der Münzaustritt nicht durch Fremdkörper oder nach geschaltete Konstruktionselemente behindert wird
---	---	---

